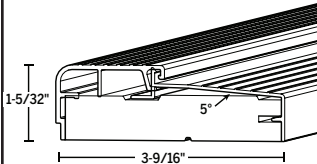
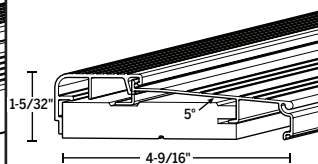
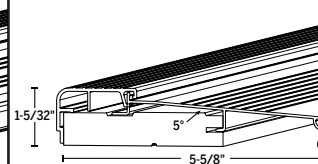
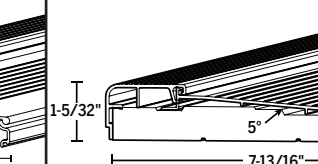
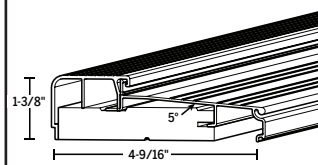
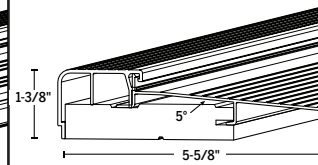
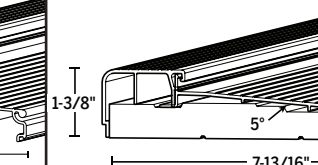
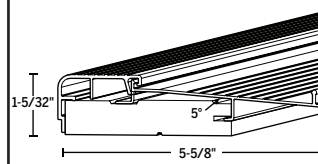
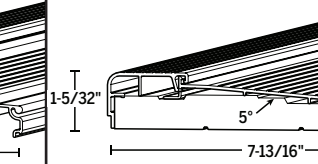
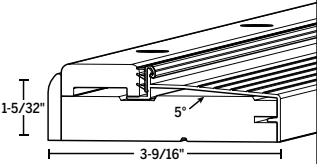
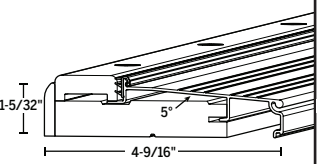
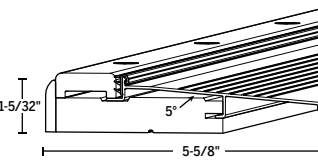
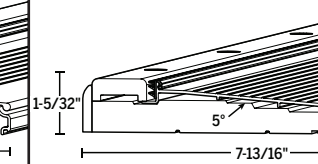
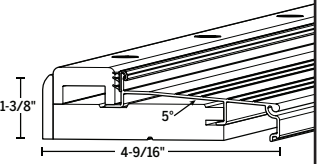
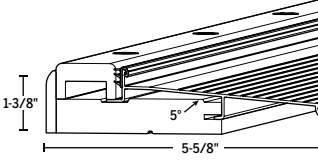
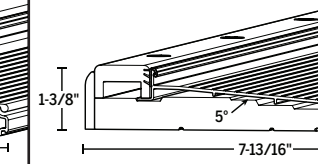
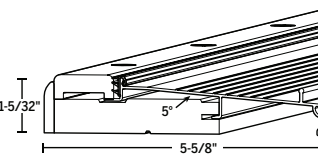
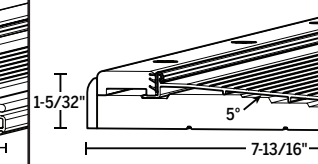

Endura Traditional Sill Options

FIXED INSWING VINYL SILLS

	3-9/16" Sills	4-9/16" Sills	5-5/8" Sills	7-13/16" Sills
Low Profile	 <p>1-5/32" 5° 3-9/16"</p> <p>FI3565V</p>	 <p>1-5/32" 5° 4-9/16"</p> <p>FI4565V</p>	 <p>1-5/32" 5° 5-5/8"</p> <p>FI5625V</p>	 <p>1-5/32" 5° 7-13/16"</p> <p>FI7815V</p>
High Profile		 <p>1-3/8" 5° 4-9/16"</p> <p>HF14565V</p>	 <p>1-3/8" 5° 5-5/8"</p> <p>HF15625V</p>	 <p>1-3/8" 5° 7-13/16"</p> <p>HF17815V</p>
Low Profile Screen Rail			 <p>1-5/32" 5° 5-5/8"</p> <p>FI5625VSR</p>	 <p>1-5/32" 5° 7-13/16"</p> <p>FI7815VSR</p>

OAK ADJUSTABLE INSWING SILLS

	3-9/16" Sills	4-9/16" Sills	5-5/8" Sills	7-13/16" Sills
Low Profile	 <p>1-5/32" 5° 3-9/16"</p> <p>AI3560</p>	 <p>1-5/32" 5° 4-9/16"</p> <p>AI45650</p>	 <p>1-5/32" 5° 5-5/8"</p> <p>AI56250</p>	 <p>1-5/32" 5° 7-13/16"</p> <p>AI78150</p>
High Profile		 <p>1-3/8" 5° 4-9/16"</p> <p>HAI45650</p>	 <p>1-3/8" 5° 5-5/8"</p> <p>HAI56250</p>	 <p>1-3/8" 5° 7-13/16"</p> <p>HAI78150</p>
Low Profile Screen Rail			 <p>1-5/32" 5° 5-5/8"</p> <p>AI56250S</p>	 <p>1-5/32" 5° 7-13/16"</p> <p>AI78150S</p>

OAK ADJUSTABLE OUTSWING SILLS

5-5/8" Sills

Block Wood Substrate

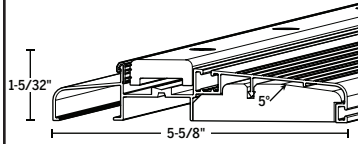

A05625AB

Full Wood Substrate

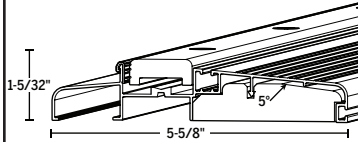

A05625AF

OAK BUMPER OUTSWING SILLS

5-3/8" Sills

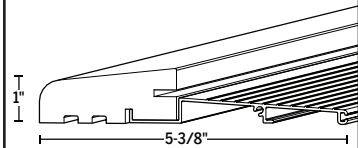

FOB53250

7-3/8" Sills

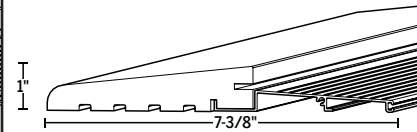

FOB73750

ALUMINUM BUMPER OUTSWING SILLS

	4-9/16" Sills	5-5/8" Sills
Block Wood Substrate	<p>4-9/16"</p> <p>6°</p> <p>1"</p> <p>FOB4565B</p>	<p>5-5/8"</p> <p>6°</p> <p>1"</p> <p>FOB5625B</p>
Full Wood Substrate	<p>4-9/16"</p> <p>6°</p> <p>1"</p> <p>FOB4565F</p>	<p>5-5/8"</p> <p>6°</p> <p>1"</p> <p>FOB5625F</p>
Block Synthetic Substrate	<p>4-9/16"</p> <p>6°</p> <p>1"</p> <p>FOBS4565B</p>	<p>5-5/8"</p> <p>6°</p> <p>1"</p> <p>FOBS5625B</p>
Full Injection Mould Substrate	<p>4-9/16"</p> <p>6°</p> <p>1"</p> <p>FOBS4565F</p>	<p>5-5/8"</p> <p>6°</p> <p>1"</p> <p>FOBS5625F</p>
Full Lineal Substrate	<p>4-9/16"</p> <p>6°</p> <p>1"</p> <p>FOBSL4565F</p>	<p>5-5/8"</p> <p>6°</p> <p>1"</p> <p>FOBSL5625F</p>

FIXED ALUMINUM OUTSWING SILLS

5-5/8" Sills

Block Substrate, Low Profile

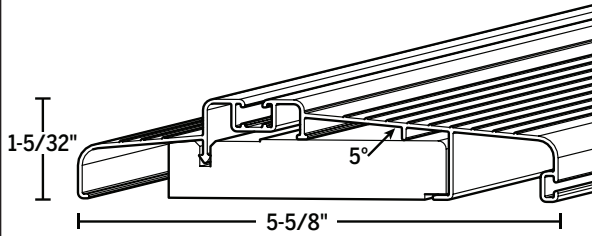

F05625AB

Full Substrate, Low Profile

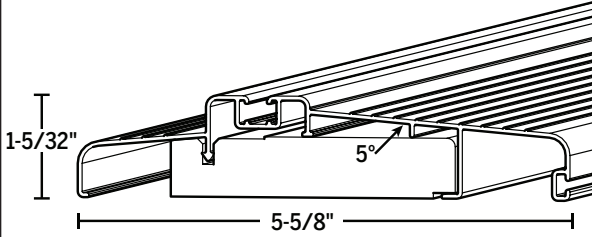

F05625AF

Block Substrate, High Profile

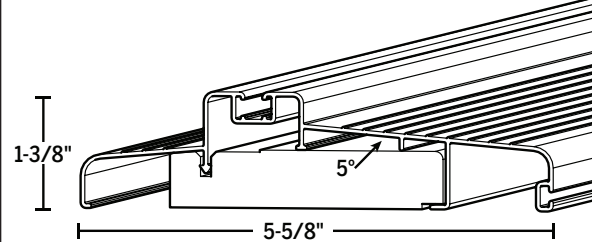

HFO5625AB

Full Substrate, High Profile

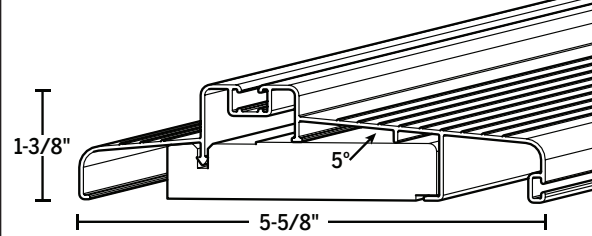

HFO5625AF