

FrameSaver[®] FusionFrame[™]

Rippable Jamb - Shop Assembly

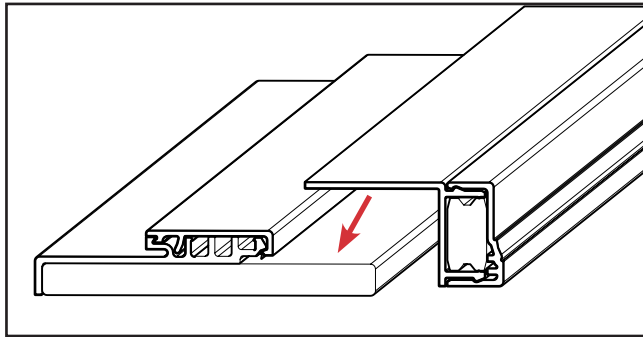

Rippable jambs and brickmould allow you to maintain the prefinished look of the FusionFrame, while still meeting the specifications of your project. The extended leg of the brickmould fits into the slot and covers the exposed portion of the core to protect it.

JAMB RIPPING:

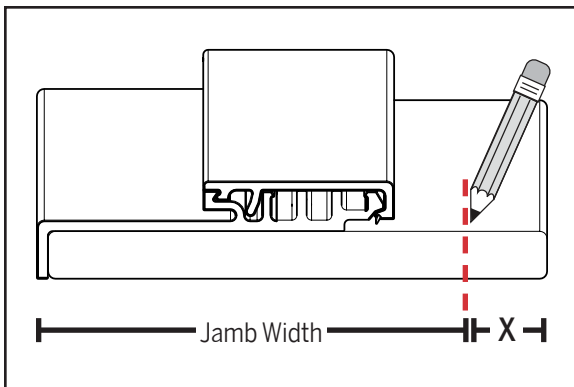

a. Determine the jamb width required and mark on the core.

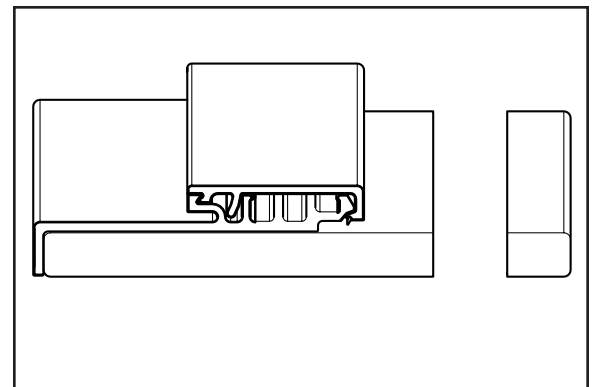

b. Rip down the jamb core based on the mark made.

* Be sure to keep the finished side facing upwards to avoid scratches

BRICKMOULD RIPPING:

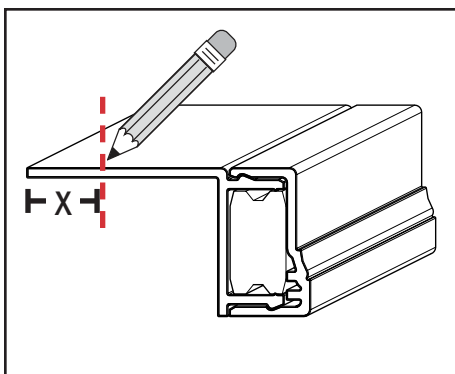

a. Measure the same distance cut off of the jamb core onto the leg of the brickmould.

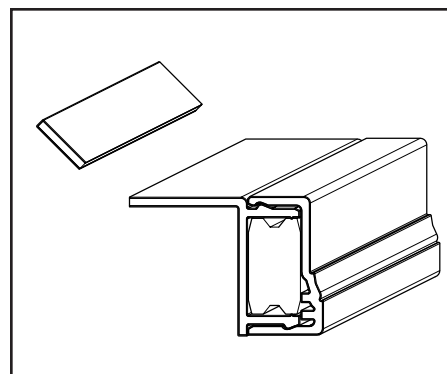

b. Cut the brickmould leg along your mark.

NOTE: A non-perpendicular cut is acceptable because brickmould leg will be hidden.

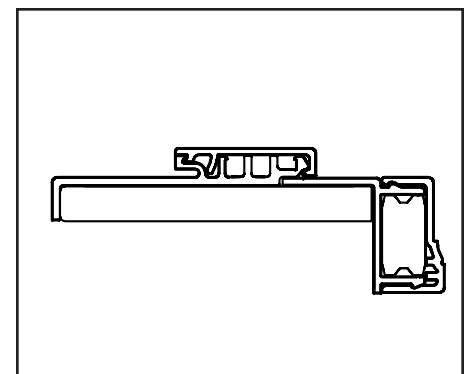

c. Check the fit of the cut jamb and brickmould. The brickmould leg should cover any remaining core.