

HOW TO CREATE A 4-7/8" JAMB

RECOMMENDED: OPTION A: Use a Width-Adjustable Jamb and Width-Adjustable Brickmould

OPTION B: Use a Width-Adjustable Jamb and Dedicated Brickmould

OPTION C: Use a Dedicated Jamb and Dedicated Brickmould

Because of the length of the brickmould leg, dedicated jambs can be extended up to 5/16" by eliminating the floating aspect of the brickmould. To properly align the dedicated jamb in the rough opening, you will need to create a spacer that will be used to align the exterior edge of the jamb with the exterior of the stud.

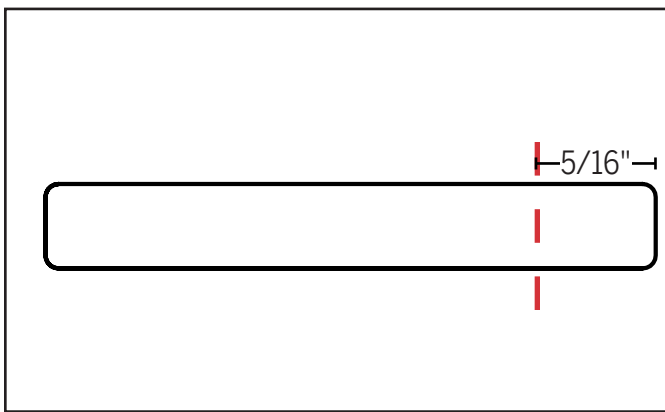

a. To make a 4-7/8" jamb out of a 4-9/16" Dedicated Jamb, start by **creating a 5/16" spacer** out of any scrap materials.

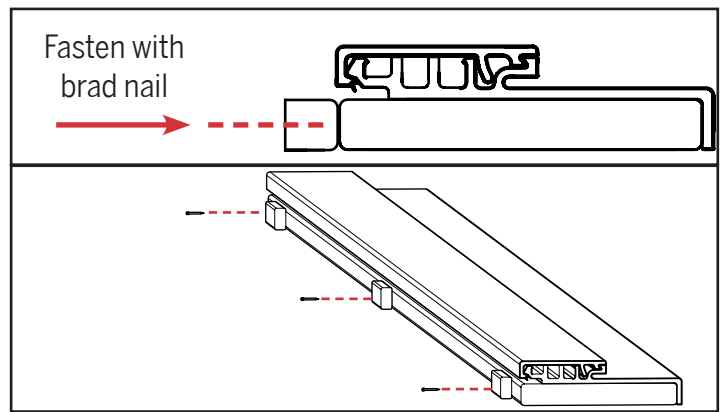

b. Using brad nails, fasten the spacers to the top of the jamb, the middle of the jamb and the bottom of the jamb.

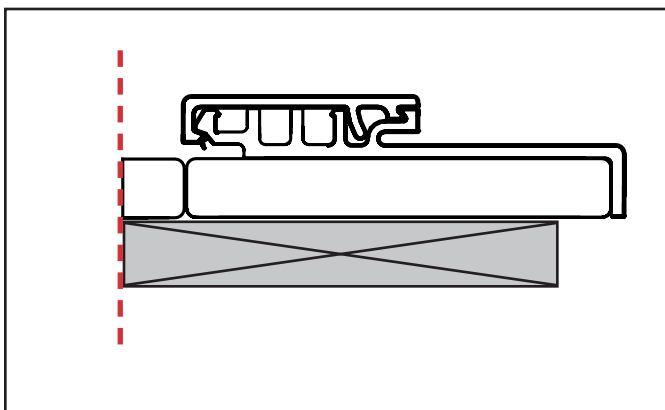

c. Align the **end of the spacer** to the **edge of the stud in the rough opening** to properly align the back of the jamb. Install the jamb as directed.

