

FrameSaver[®] FusionFrame[™]

Mull Extender Assemblies

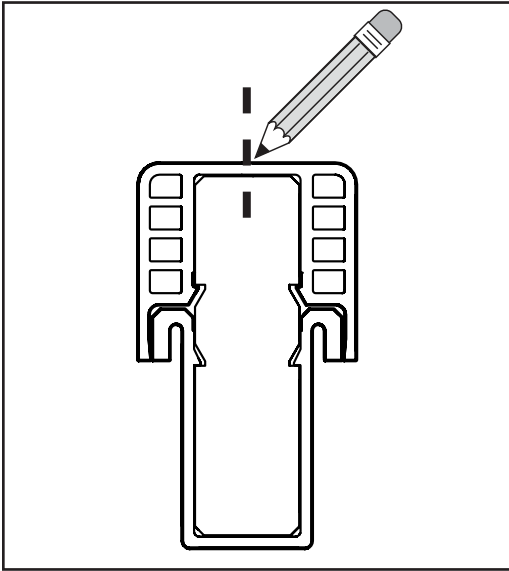

a. Locate and mark the center point on the face of the mull.

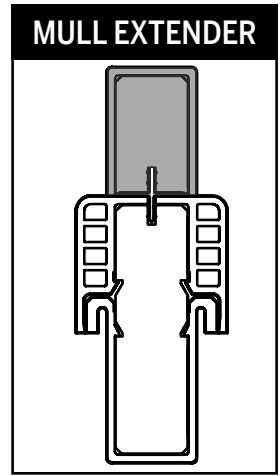
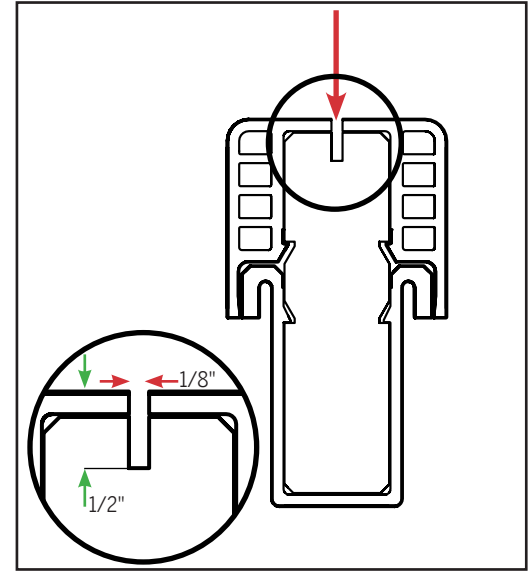

b. Using a 1/8" saw blade, make a cut along the center line of the mull that is a minimum of 1/2" deep.

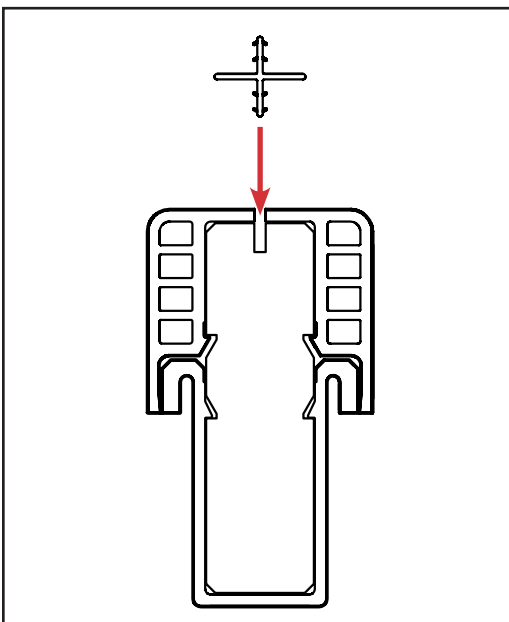

c. Insert the Mull Extender Attachment into the newly created slot.

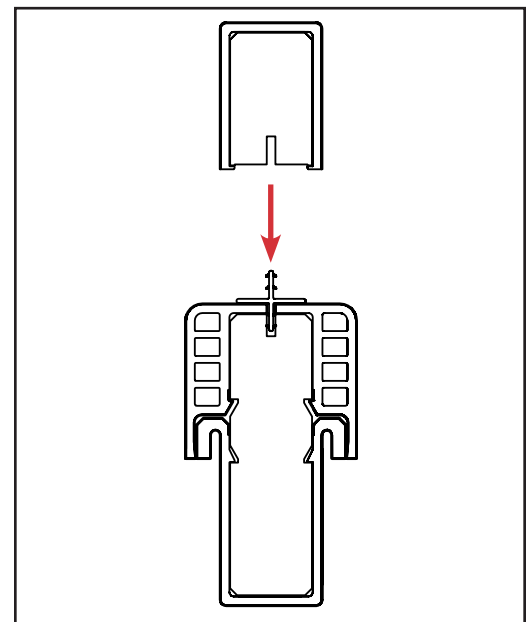

d. Insert the Mull Extender onto the attachment.*

*MULL EXTENDER RIP DOWN

Mull Extenders are sold at 2-1/8" lengths, but can be ripped down to meet the needs of your door system.

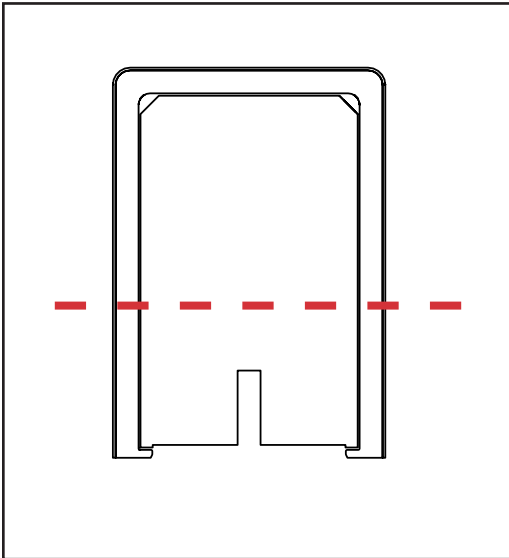

a. Cut down the mull extender to the length needed. Cut off from the unfinished side to protect the prefinished appearance.

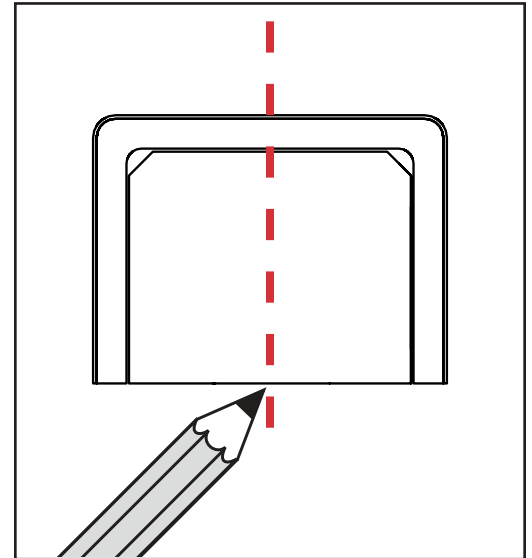

b. Locate and mark the center point on the newly cut mull extender.

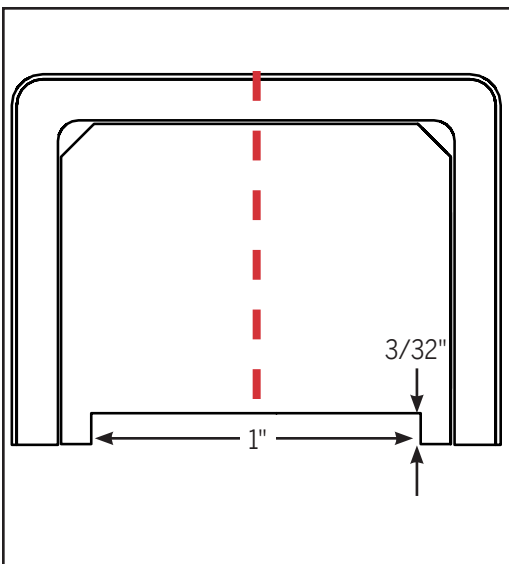

c. Using a 1" router bit on a table router, make a 3/32" deep groove that is 1" wide centered on the marked center point, allowing the mull extender attachment to be recessed in the extender.

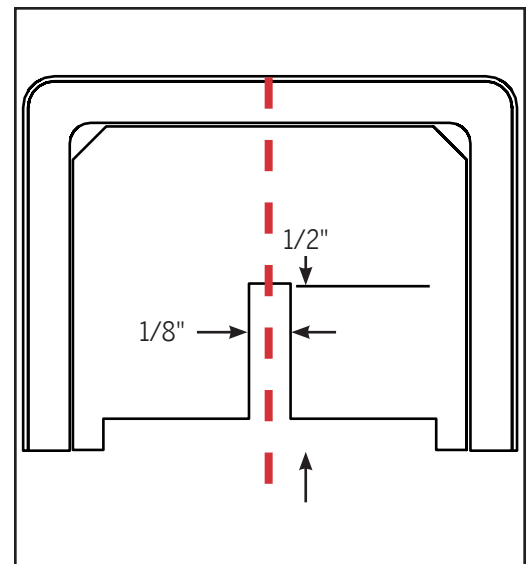

d. Using a 1/8" saw blade, make a 1/2" deep cut ON the center point.