

## Product Description and Reference Guide

### Weatherstrip Locations

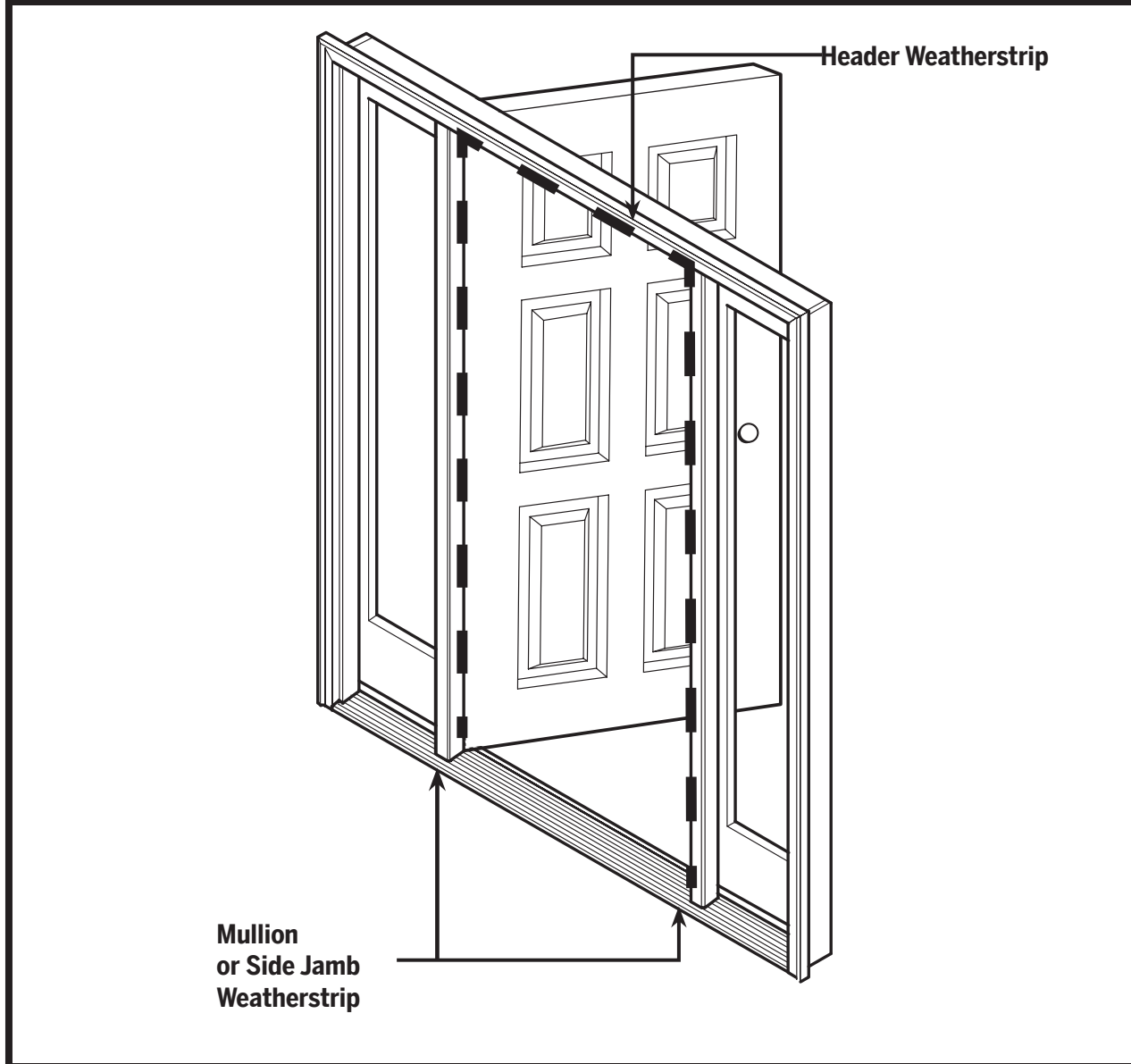

### Side View of Weatherstrip

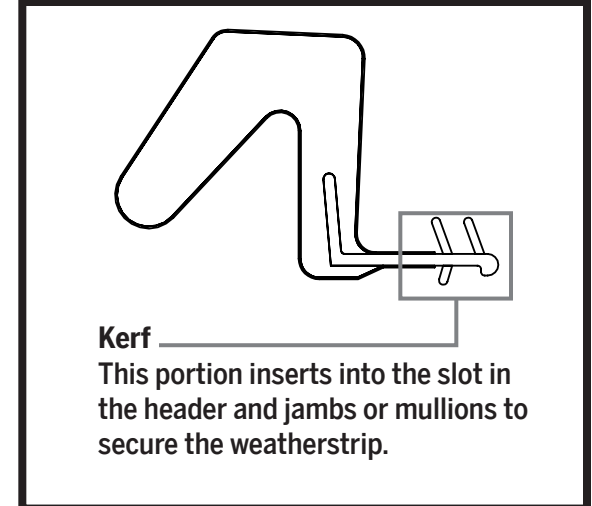

### Top Down View of Side Jamb

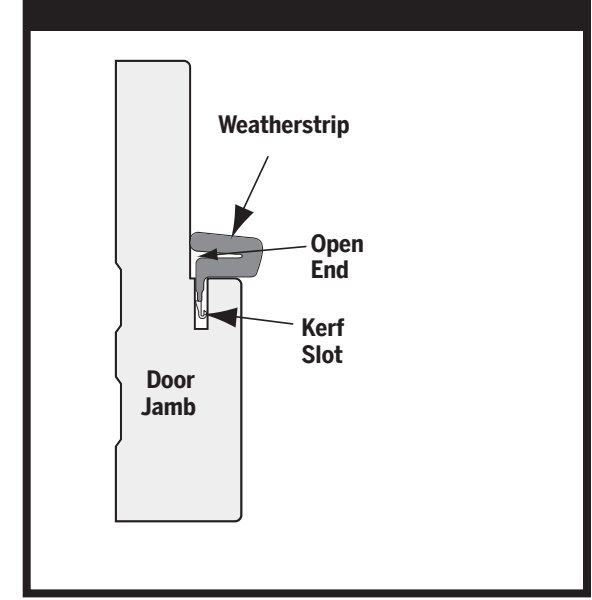

# Weatherstrip Replacement Instructions

8817 West Market Street  
Colfax, NC 27235  
800.334.2006  
www.enduraproducts.com



## Required Tools

- 1. Small Flathead Screw Driver:** for removing old weatherstrip remnants.
- 2. Needle Nose Pliers:** for removing old weatherstrip remnants.
- 3. Scissors:** to cut weatherstrip to size.
- 4. Marker:** to measure the needed length of weatherstrip

## 1 Remove Existing Weatherstrip

Remove OLD weatherstrip by grasping on one end, then pulling from jamb along its length.

**! NOTE:** Aged or damaged weatherstrip may break or tear. It may be necessary to remove weatherstrip or remnants with a small screw driver or needle nose pliers. Take care to not damage the frame.

Top Corner of Door Opening

## 2 Clean All Door Jamb

Thoroughly clean all door jambs including header and side jambs. Clean bottom corners and the inside of the door jamb.

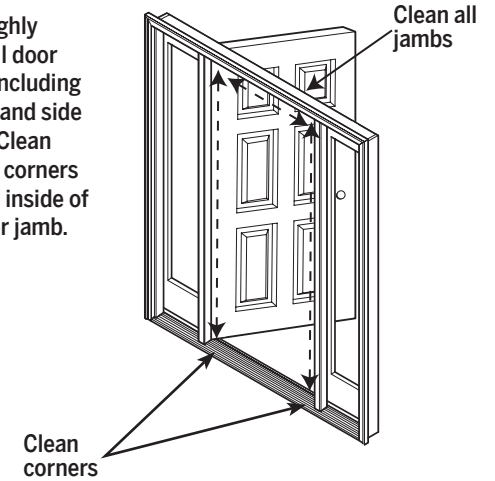

## 3 Measure and Cut Weatherstrip for Door Jamb Header

- Measure the door header width.
- Cut a piece of the weatherstrip to match the header width size.

**! Make sure to cut the weatherstrip ends square and even.**

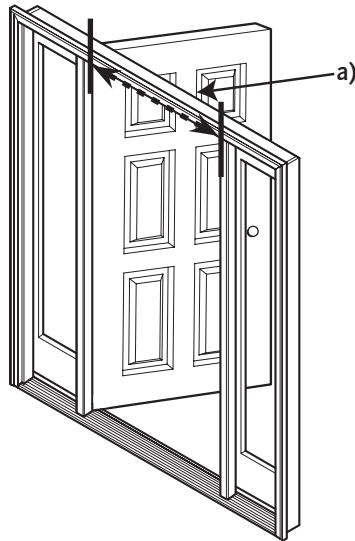
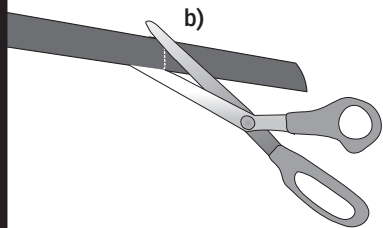

## 4 Insert Weatherstrip Into Door Jamb Header

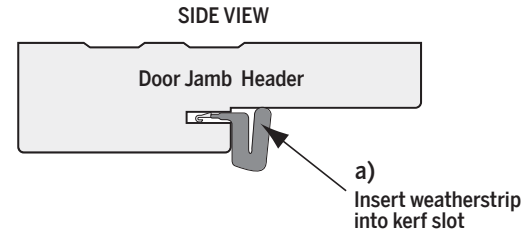

a) Insert weatherstrip kerf into the door header kerf slots with open side facing upwards, as shown.

b) Place end of weatherstrip up to side door jamb face at the top corner.

c) Starting at one end, press the weatherstrip firmly across entire length of door jamb header to secure into the kerf slot.

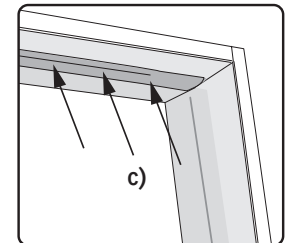
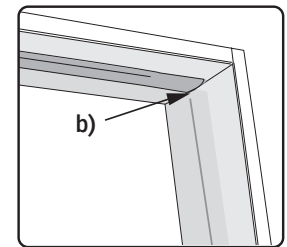

# Weatherstrip Replacement Instructions

8817 West Market Street  
Colfax, NC 27235  
800.334.2006  
www.enduraproducts.com



## 5 Measure and Cut Weatherstrip for Side Jamb

a) Measure the left and right side jamb or mullion length and subtract 1/8" from the measurement.

b) Mark the weatherstrip at the same length and cut.

⚠ Make sure to cut the weatherstrip ends square and even.

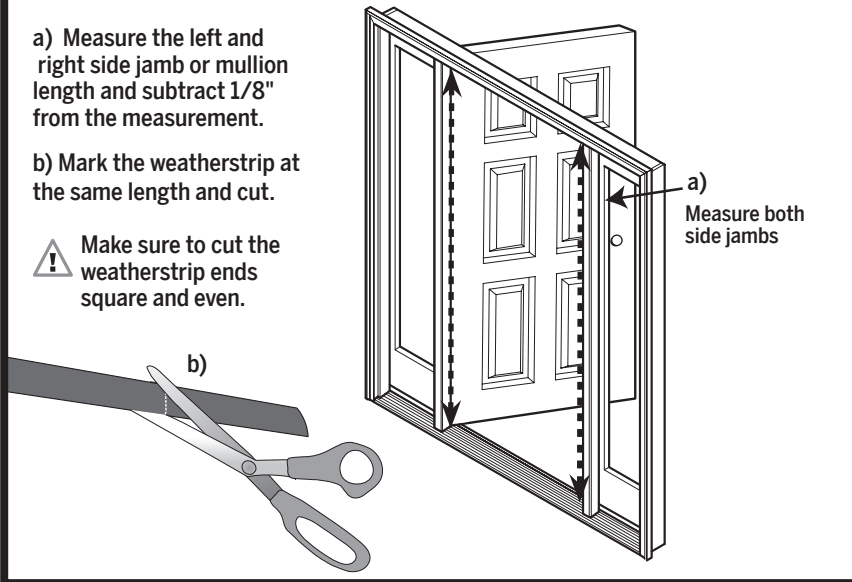

## 6 Insert Weatherstrip Into Jamba

a) Insert weatherstrip into the side jamb kerf slots with open side facing towards the door jamb as shown.

b) Place end of the new weatherstrip up against the header weatherstrip at the top corner.

c) Starting at the top, press the weatherstrip firmly down the entire length of the jamb to secure into the kerf slot.

d) Repeat for the other side jamb.

