

# Endura Staple-On Door Bottom for 2-1/4" Doors

## Installation Instructions



### TOOLS AND SUPPLIES:

- Phillips Screwdriver or Drill
- Putty Knife
- Marker
- Cutting Tool (Chop/Miter Saw **strongly** recommended)
- Exterior Grade Caulk
- Staple Gun
- 1/2" x 1/2" Staples
- Flat workspace, large enough for door panel

### STEP 1: REMOVE EXISTING DOOR PANEL FROM THE FRAME - WE RECOMMEND HAVING ANOTHER PERSON ASSIST WITH THIS STEP

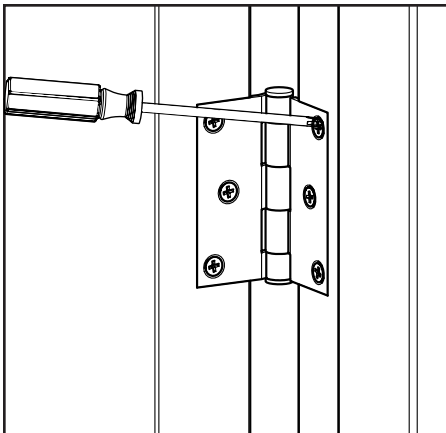

a. Open the door and locate the hinges. Using a Phillips screwdriver or drill, remove the screws from the hinge plate on the jamb.

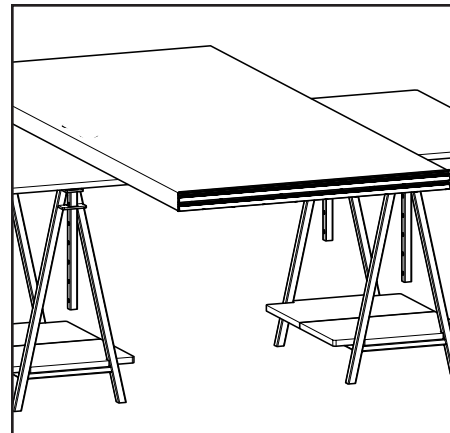

b. When door is loose from frame, carry it to a flat workspace where the panel can be laid horizontally.

## STEP 2: REMOVE THE OLD DOOR BOTTOM FROM THE PANEL

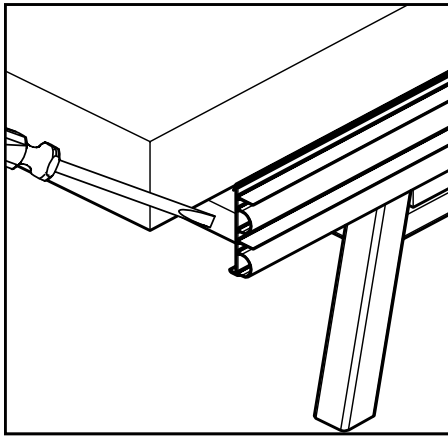

a. Remove the old door bottom from the door panel. Use a flathead screw driver to pry the end of the door bottom off the panel.

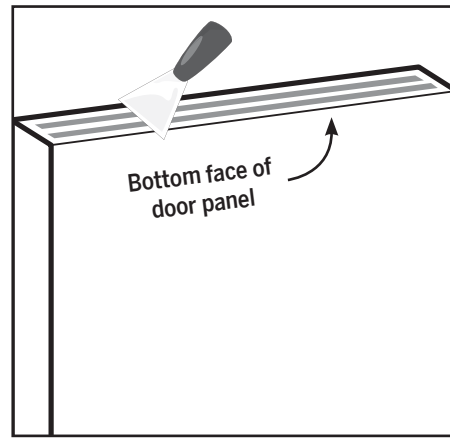

b. Remove any old residue or staples from the door panel's bottom face, using a putty knife or similar tool.

## STEP 3: PREPARE THE NEW DOOR BOTTOM

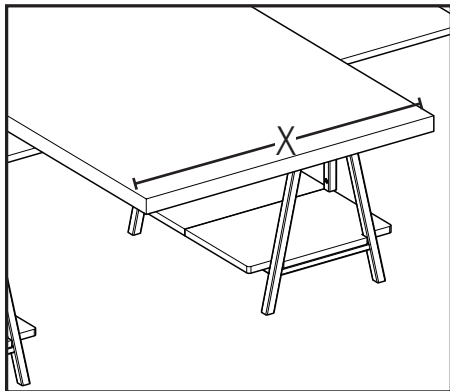

a. Measure the width of the door panel (X).

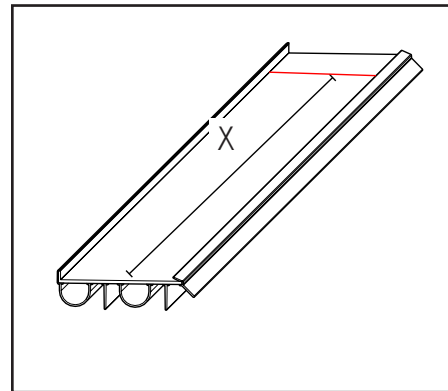

b. Measure and mark the same width (X) on the door bottom, measuring from one end. Cut the door bottom along that line.

## STEP 4: CAULK THE NEW DOOR BOTTOM

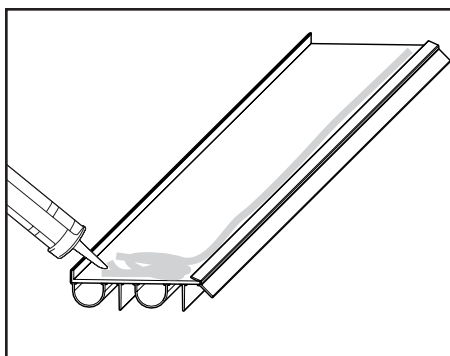

a. Apply exterior grade caulking along the edge of the door bottom that will be facing the exterior of the home. Thoroughly caulk each end of the door bottom.

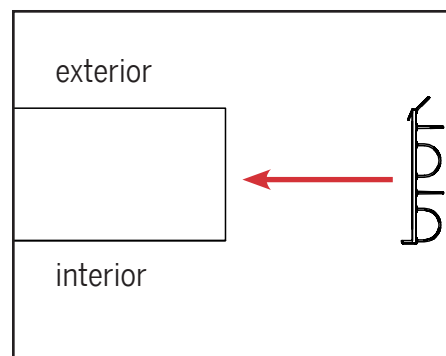

b. Orient the door bottom with the door panel as shown above.

## STEP 5: INSTALL THE NEW DOOR BOTTOM

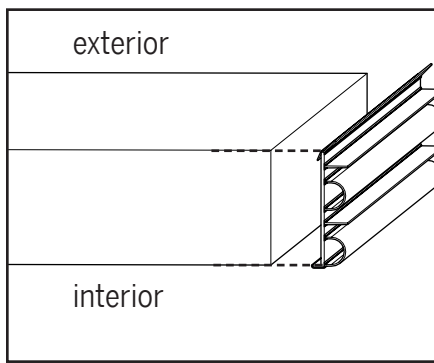

a. Align one end of the door bottom with the door panel edge on the lock side.

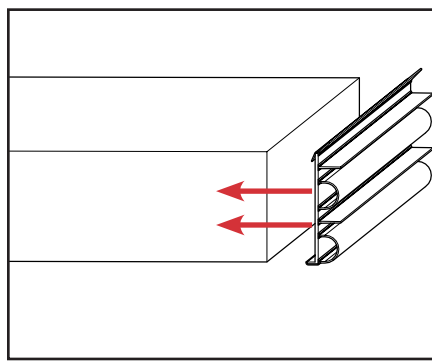

b. Using hand pressure, press the door bottom flush against the bottom of the door panel. Make sure the door bottom is flush down the length of the panel and square at the ends.

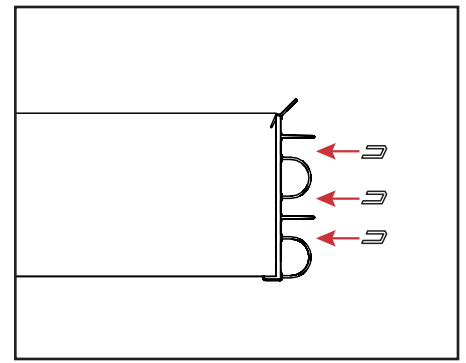

c. Secure one end with a 1/2" x 1/2" light gauge staple. Continue stapling down the length of the door panel in 6 inch increments. Wipe away excess caulking.

## STEP 6: RETURN THE DOOR PANEL TO THE FRAME - WE RECOMMEND HAVING ANOTHER PERSON ASSIST WITH THIS STEP

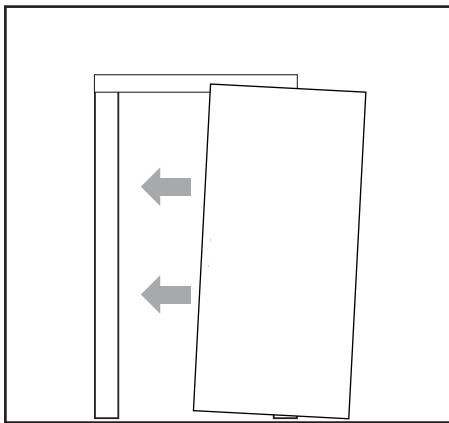

a. Realign the door panel with the hinges in the frame.

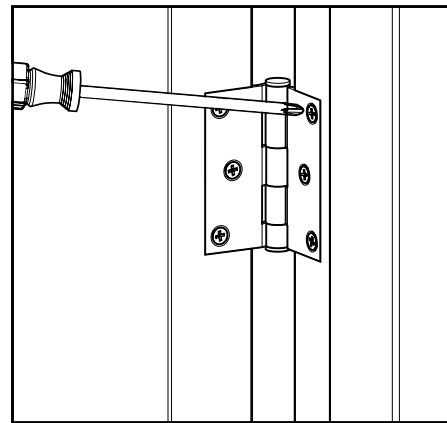

b. Reattach the hinges to the jamb with the screws previously removed. Confirm the door operates properly.