

Trilennium® 3020 Multi-Point Locking System - Header and Sill Strike Kit

Installation Instructions

TOOLS REQUIRED:

- Screwdriver or Drill

LOCK SYSTEM INCLUDES:

- Trilennium 3020 Series French Mortise Lock
- 1-1/2" FHSMS Mortise Lock Mounting Screws (7: not all are used, depending on length of lock)

HEADER AND SILL STRIKE KIT SOLD SEPARATELY (TC-STRKPKK-SGL-XX)

- Strike Plates for Header and Sill (2)
- 2-1/2" FHSMS Strike Mounting Screws (6)
- 3/4" FHSMS Strike Mounting Screws (4)
- 1-3/16" Flat Head Machine Screws (2)

REINFORCING STRIKE KIT - TYPICALLY INCLUDED WITH PURCHASE OF TL-3000 OR TL-3070 ACTIVE PANEL LOCK

- Reinforcing Strike Plates with Rollers (3)
- Strike Plates (3)
- 2-1/2" FHSMS Strike Mounting Screws (3)
- 3/4" FHSMS Strike Mounting Screws (6 - only 3 used with 3020 Lock)

Note: The door panel and astragal must be routed for the 3020 Lock prior to install.

Part A: Install the Lock and Astragal

STEP 1: INSERT AND SECURE LOCK INTO ROUTED SLOT

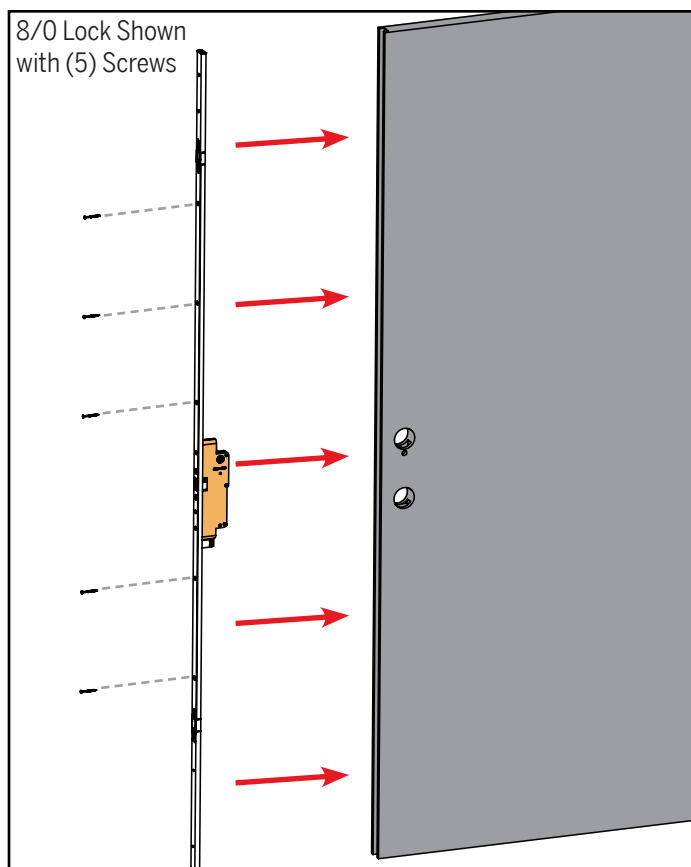

a. Insert the Trilennium 3020 Lock into the routed slot in the inactive door panel.

b. Secure the lock using 1-1/2" FHSMS Mortise Lock Mounting Screws.

- 6/8 Locks use 4 screws
- 8/0 Locks use 5 screws
- 9/0 Locks use 6 screws
- 10/0 Locks use 7 screws

STEP 2: INSTALL ASTRAGAL ONTO DOOR PANEL

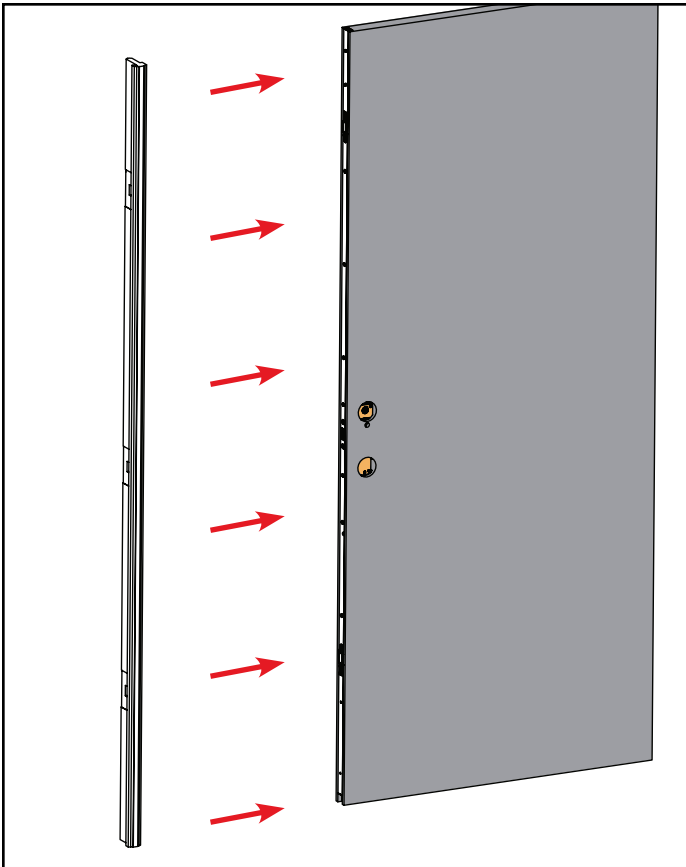

- a. Install the routed astragal over the lock and onto the door panel.

STEP 3: INSTALL REINFORCING STRIKE KITS

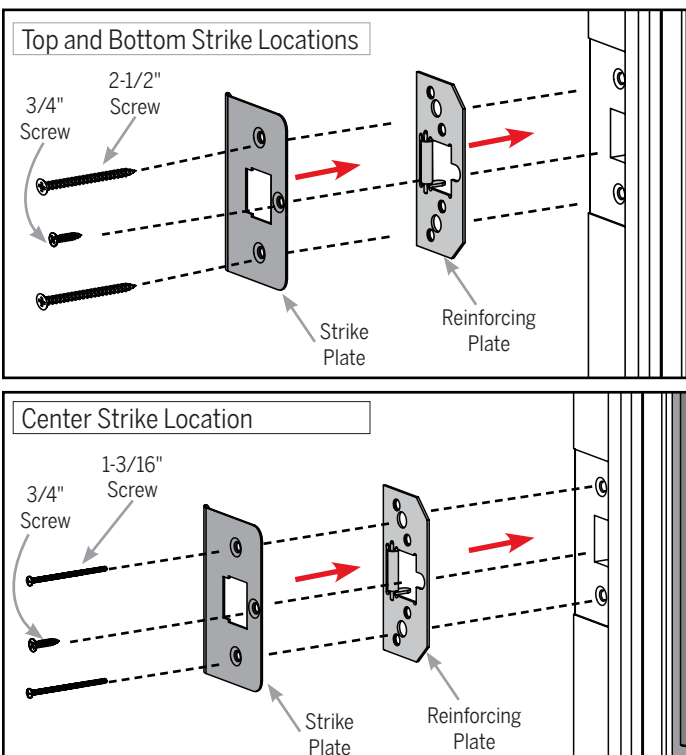

Align the three holes on the strike plate with the reinforcing plate and install on the astragal, ensuring the appropriate screws are used at each location.

a. For Top and Bottom Strikes:

- i. Use 2-1/2" screws in the top and bottom holes of each strike plate.
- ii. Use 3/4" screw in center hole.

b. For Center Strike:

- i. Use 1-3/16" screws in the top and bottom holes of the strike plate, through the Trilennium 3020 Mortise Lock.
- ii. Use 3/4" screw in center hole.

Part B: Install the Head and Sill Strike Plate

STEP 4: DETERMINE PLACEMENT OF HEADER STRIKE PLATE

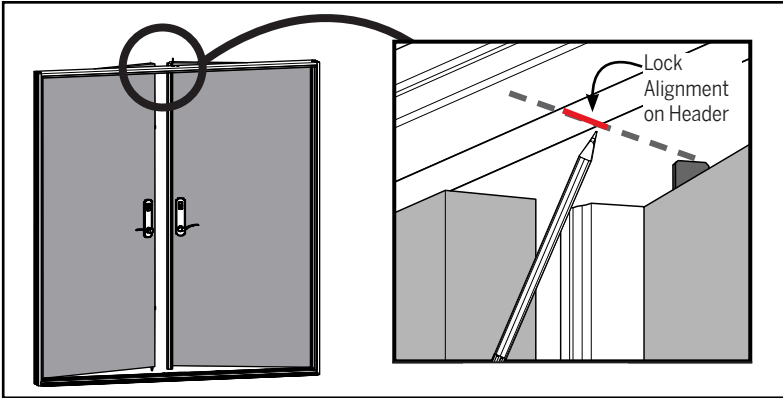

a. Close the inactive door and engage the lock. Mark the area where the lock will meet the header. This will serve as a reference point to mount the strike plate.

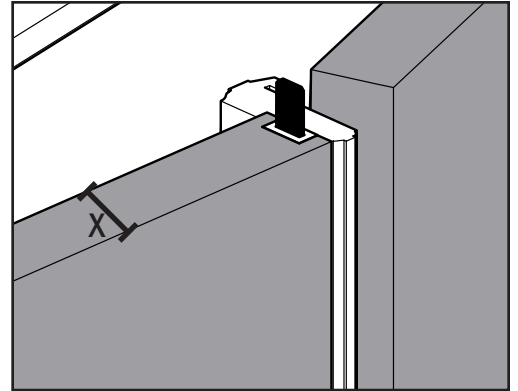

b. Measure the thickness of the door panel (X).

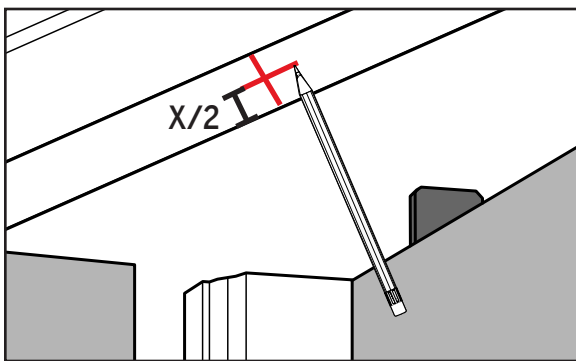

c. Divide this thickness (X) in half and mark that distance on the header. This will help you center the plate.

STEP 5: SCREW PLATE IN TEMPORARILY

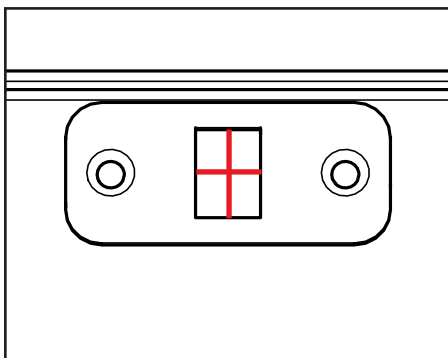

a. Using the marks you have made in Steps 4a and 4c, line up the strike plate on the header.

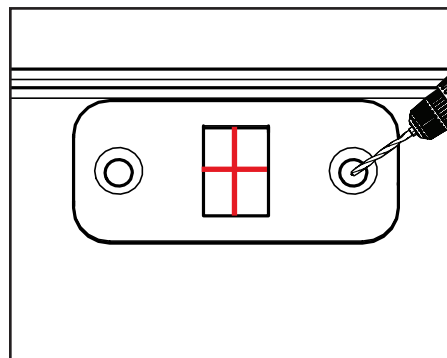

b. Spot drill the location for the screw holes.

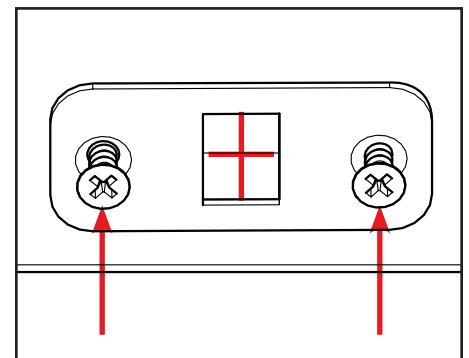

c. Temporarily secure the plate on the header using the 3/4" mounting screws.

STEP 6: DRILL THE HOLE FOR THE LOCK

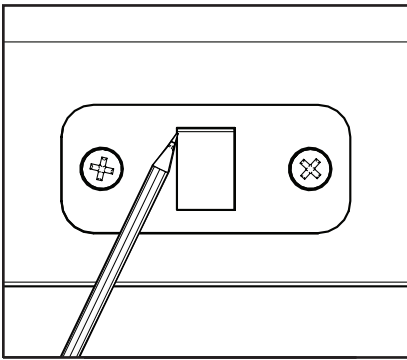

a. Trace the rectangular space of the strike plate with a pencil to use as a template to drill the hole.

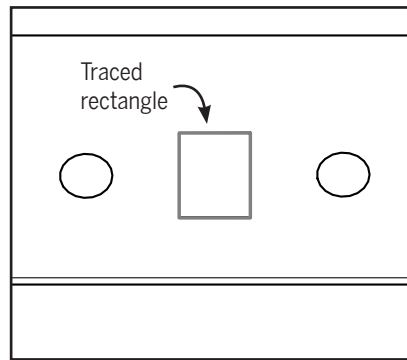

b. Unscrew and remove the strike plate.

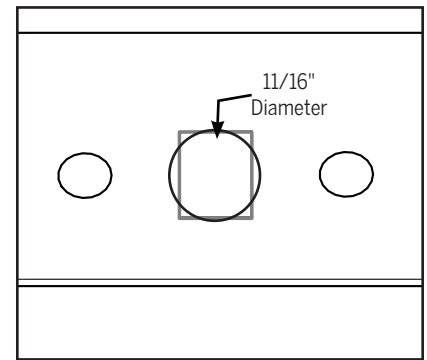

c. Drill into the header using an 11/16" diameter drill bit to create a space at least 1" deep.

STEP 7: SECURE STRIKE PLATE ONTO HEADER

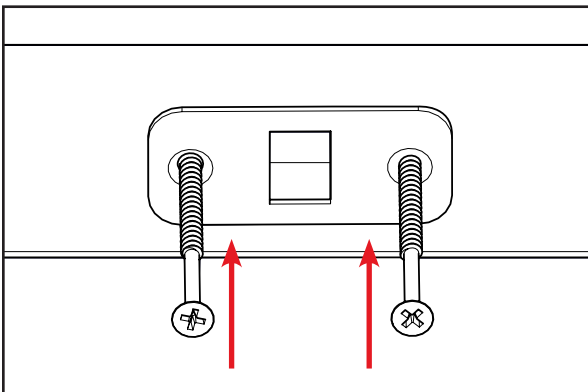

a. Return the strike plate to the exact position it was before (Step 5) and screw into place.

STEP 8: DETERMINE PLACEMENT OF SILL STRIKE PLATE

FOR INSWING SILLS:

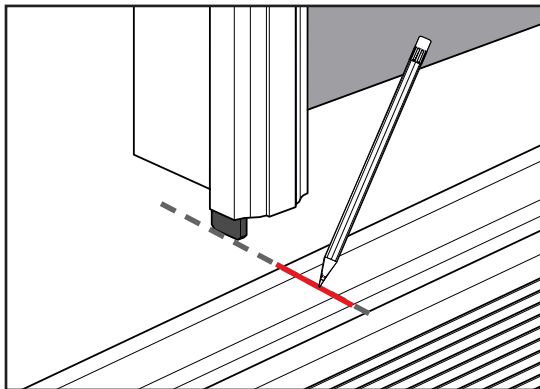

a. Close the inactive door and engage the upper and lower lock. Mark where the lock meets the sill cap. This will serve as a reference point to mount the strike plate.

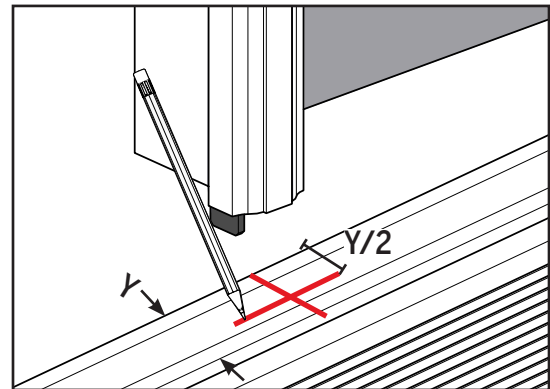

b. Measure the width of the sill cap (Y) and mark the center point (Y/2).

STEP 8 (CONT.): DETERMINE PLACEMENT OF SILL STRIKE PLATE

FOR OUTSWING SILLS:

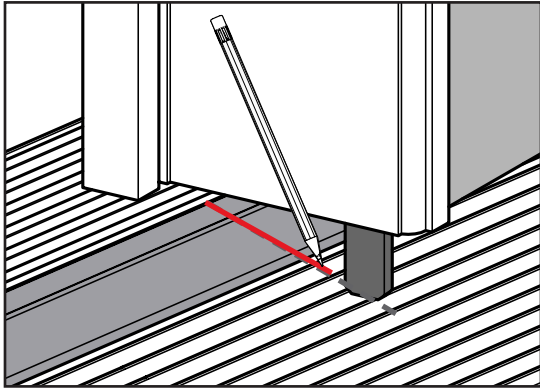

a. Close the inactive door and engage the upper and lower lock. Mark where the lock meets the sill cap or deck. This will serve as a reference point to mount the strike plate.

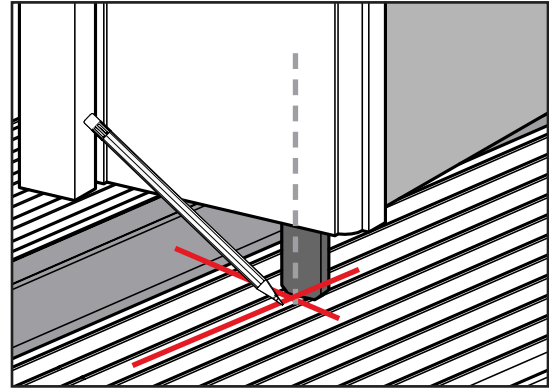

b. Close the door and mark the centerline of the door panel onto the sill deck.

STEP 9: SCREW IN PLATE TEMPORARILY

INSWING

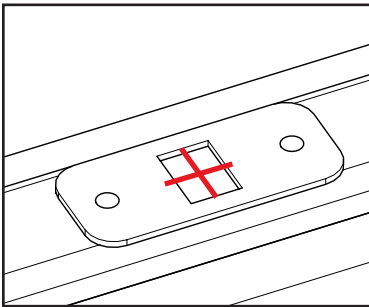

OUTSWING

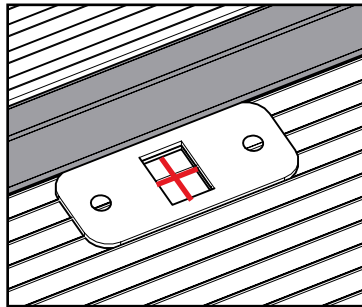

a. Using the marks you have made in Step 8, line up the strike plate on the sill cap or deck.

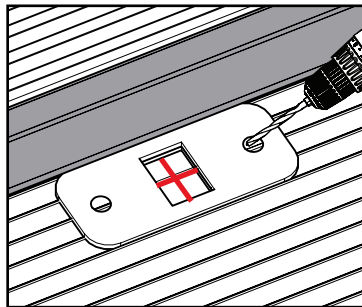
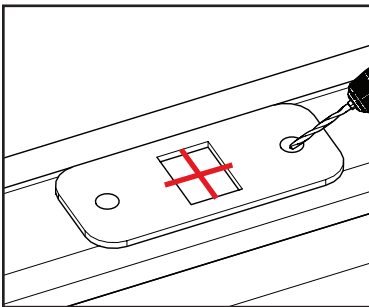

b. Spot drill the location of the screw holes.

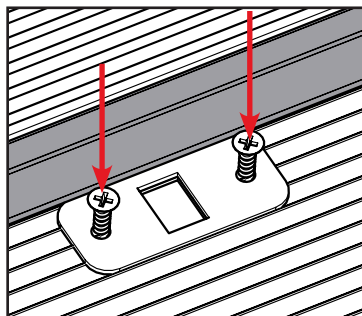
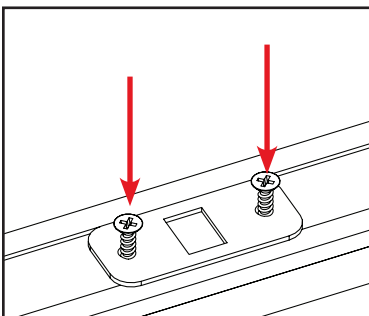

c. Temporarily secure the plate to the sill using the 3/4" mounting screws.

STEP 10: DRILL THE HOLE FOR THE BOLT

INSWING

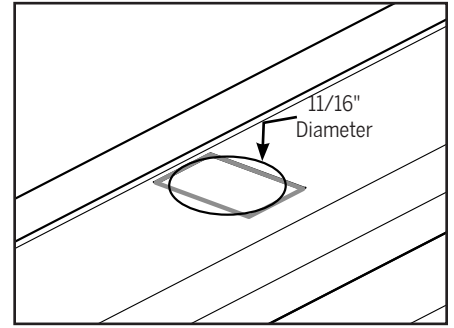
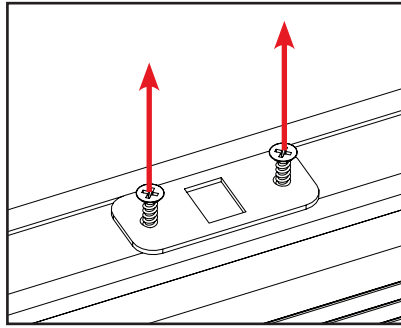
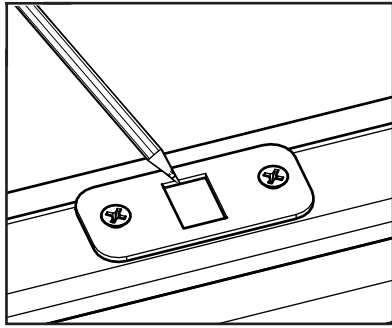

OUTSWING

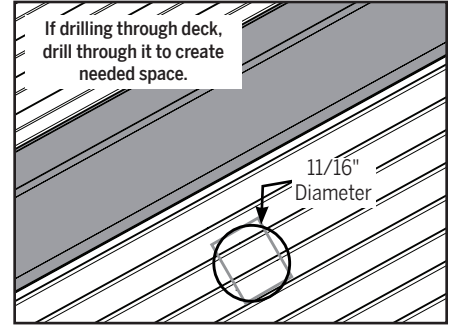
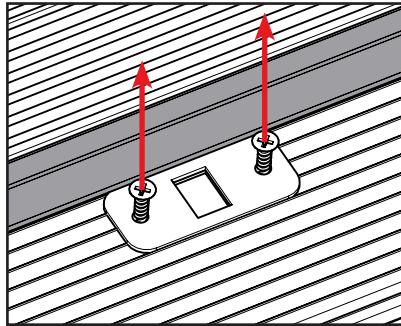
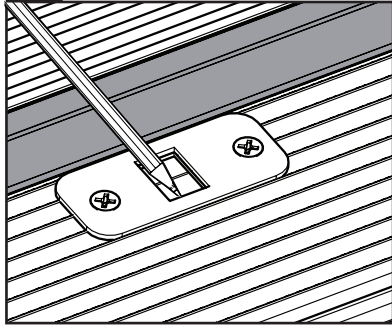

a. Trace the rectangular space of the strike plate with a pencil to use as a template to drill the holes.

b. Unscrew and remove the strike plate.

c. Drill into the sill cap or deck using an 11/16" diameter drill bit to create a space at least 1" deep.

STEP 11: SECURE STRIKE PLATE ONTO SILL

INSWING

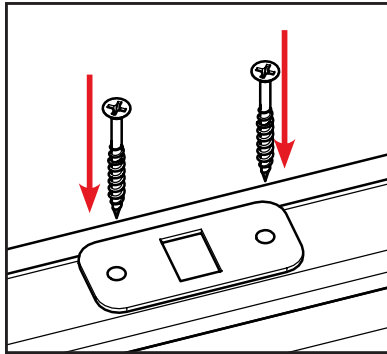

OUTSWING

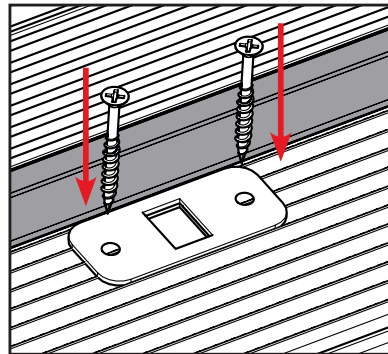

a. Return the strike plate to the exact position it was before (Step 9 & 10) and screw into place.

STEP 12: CONFIRM PROPER INSTALLATION

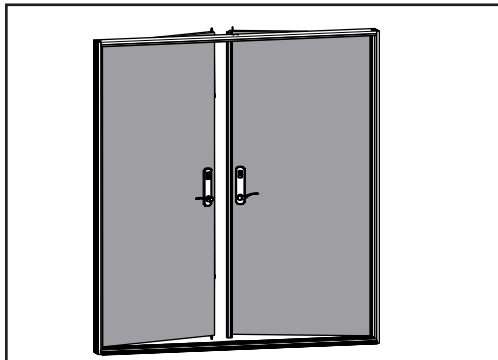

a. Close and lock the inactive door to ensure the proper placement of the strike plates.

The information contained in this document is the confidential and proprietary information and trade secrets of Endura Products, Inc. Any disclosure, use or dissemination of such information without the express written permission of Endura Products, Inc. is strictly prohibited. Endura Products, Inc. also owns any and all intellectual property rights embodied in such information, including patent rights, copyrights, and trademark rights, and no license of any intellectual property right is intended, nor should any license be implied, as a result of the receipt of this document.
Rev. 09.11.2017



8817 West Market Street, Colfax, NC 27235
800.334.2006 Fax: 336.668.4478
www.enduraproducts.com