

Shortening the 3020 Series French Mortise Lock

Top of lock



Note – When resizing the Trilennium 3020 for use on a shorter door panel it may be necessary to modify the length of lock at one or both ends. This instruction details cut down steps which apply to either end.

Tools Required

- T-15 Torx driver
- Flat head screwdriver
- Mallet or hammer
- Hacksaw
- Hand file

1.) Determine Cut Down Length and Location

- Measure distance between center of door panel deadbolt bore and top and bottom edges of the panel.
- Transfer measurements to the side face of the existing Trilennium 3020 lock.
- Lock cut down is required where the lock extends past the door panel measurements

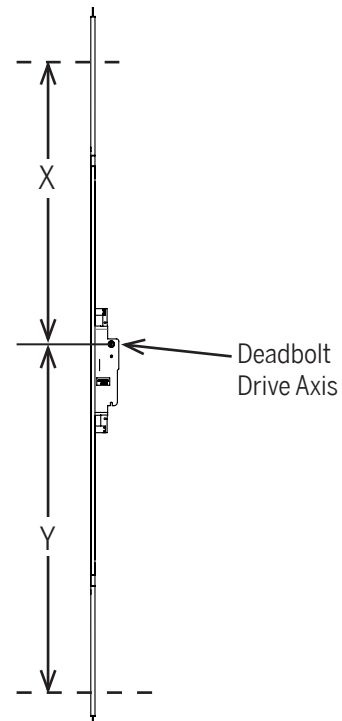
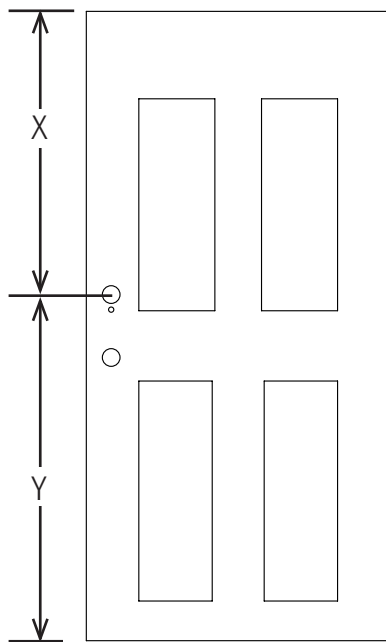

Bottom of lock

2.) Disassemble Existing Lock

- Position lock to expose back side
- Remove (2) locking bolt screws, then slide bolt from lock body.
- Remove end cap with screwdriver and mallet
- Remove screw guide with screwdriver and mallet.

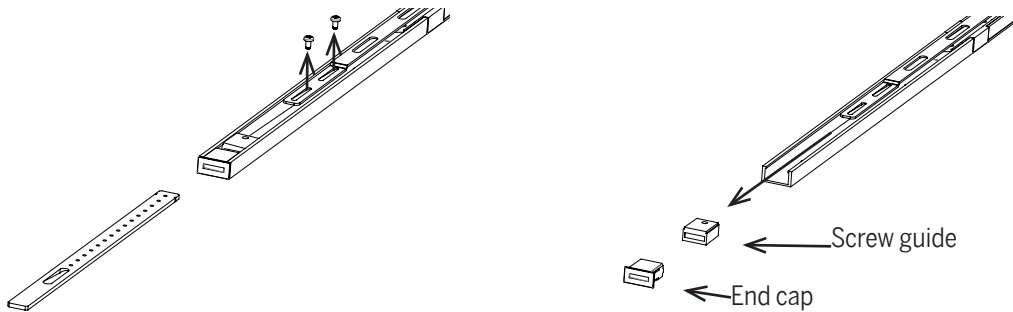

3.) Resize Lock

- At the location previously marked on the lock side face, cut the lock channel to the new length
- Ensure the cut is square.
- Drill a 7/32" hole as shown.
- Remove any burrs or chips.

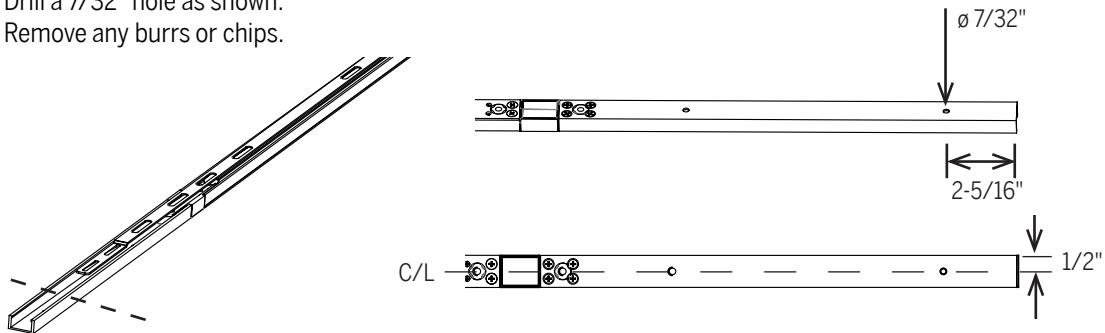

4.) Reassemble Lock

- a. Insert screw guide into lock channel as shown. Align with newly drilled hole by placing the drill bit through channel and guide holes. Crimp guide into place by notching the channel edge with a flat head screwdriver and hammer.
- b. Insert end cap into lock channel as shown. Crimp cap into place by notching the channel edge with a flat head screwdriver and hammer.
- c. Slide bolt through end cap, bolt guide, and under drive linkage as shown.
- d. Secure bolt by tightening screws.

a1. Insert Screw Guide

a2. Crimping Screw Guide

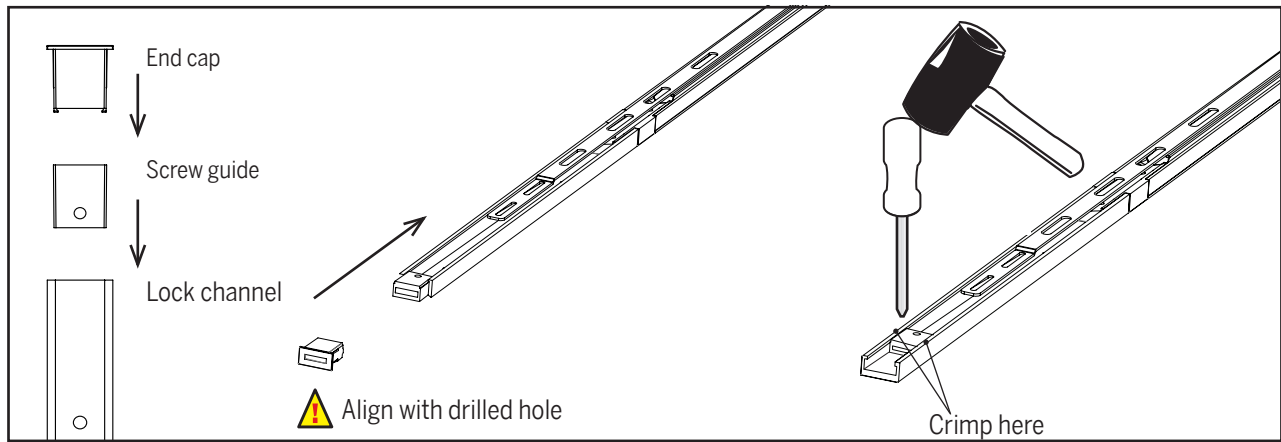

b. Insert and crimp End Cap.

c. Reinstalling Locking bolt

d. Reinstalling Screws

