

ADA Sill Assembly Instructions



8817 West Market Street
Colfax, NC 27235 | 800.334.2006
www.enduraproducts.com

TOOLS REQUIRED:

- Drill with 1/8" Drill Bit
- Measuring Tape
- Marker

INSWING Z-SERIES ADA SILL

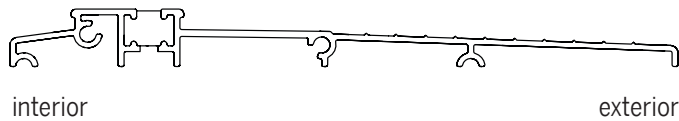

OUTSWING Z-SERIES ADA SILL

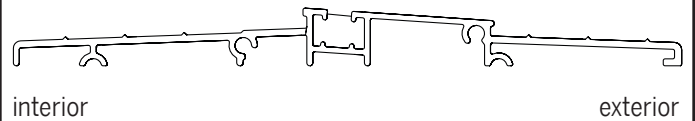

TILEBACK Z-SERIES ADA SILL

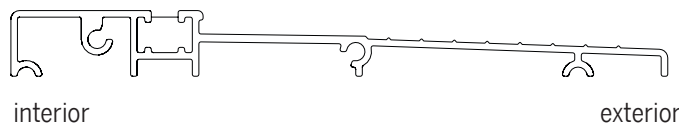

TILEBACK SADDLE ADA SILL

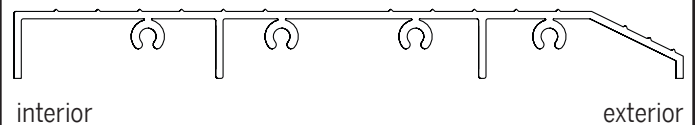

SADDLE ADA SILL

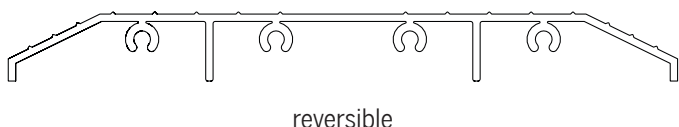

TABLE OF CONTENTS

Jamb Modifications for ADA Compliant Sills:

- » Inswing Z-Series Sills (Pages 2-3)
- » Outswing Z-Series Sills (Pages 3-4)
- » Saddle Sills (Page 4)

Sill and Jamb Assembly Instructions (Page 5)

JAMB MODIFICATIONS FOR ADA COMPLIANT SILLS

Cut an inswing jamb to match one of the below diagrams that corresponds with the ADA sill being installed.

Note: Modifications are based on starting with an Inswing Jamb with a Z-Series Tenon.

INSWING Z-SERIES ADA SILLS

Jamb Modifications for 4-9/16", 5" or 5-5/8" Inswing Sills

Jamb Modifications

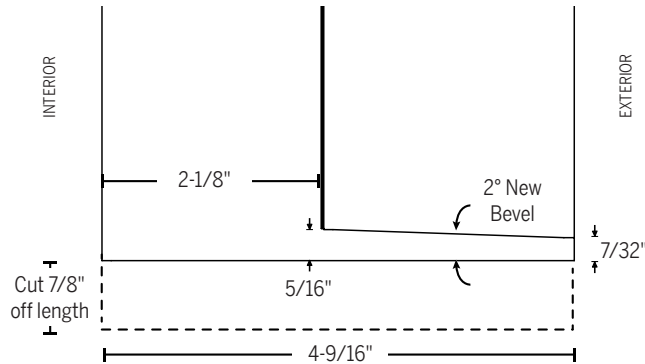

Screw Hole Pattern

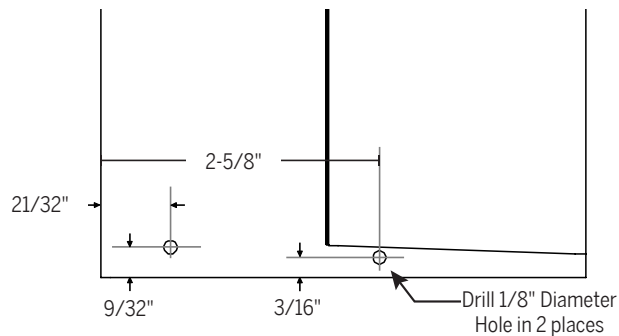

Jamb Modifications for 6-9/16" or 7" Inswing Sills

Jamb Modifications

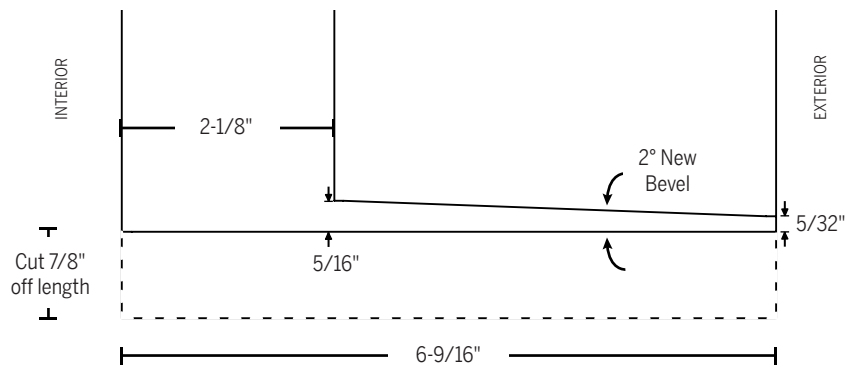

Screw Hole Pattern

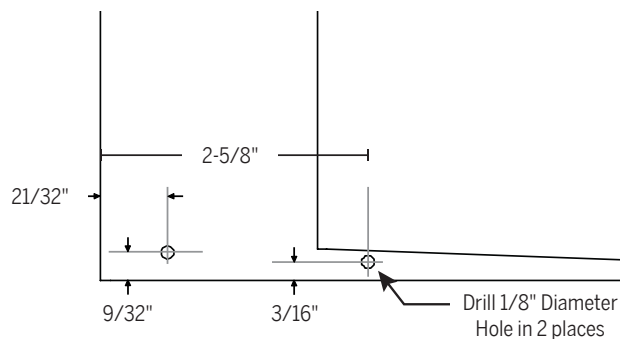

Jamb Modifications for 7-9/16" Inswing Sills

Jamb Modifications

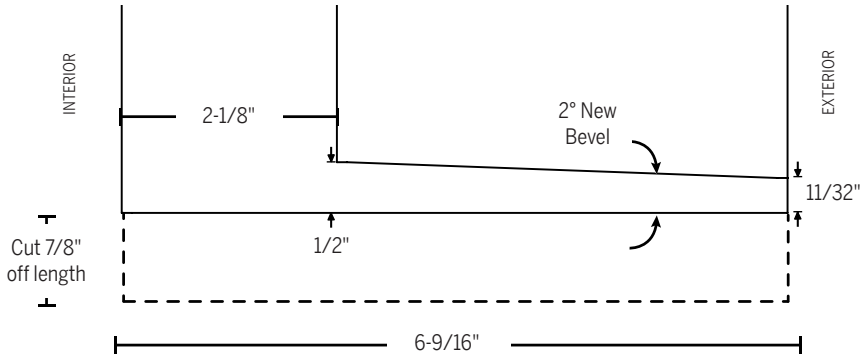

Screw Hole Pattern

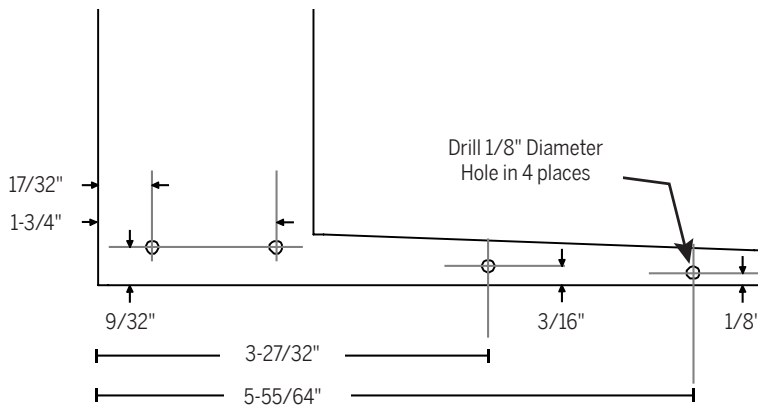

OUTSWING Z-SERIES ADA SILLS

Jamb Modifications for 5-5/8" Outswing Sills

Jamb Modifications

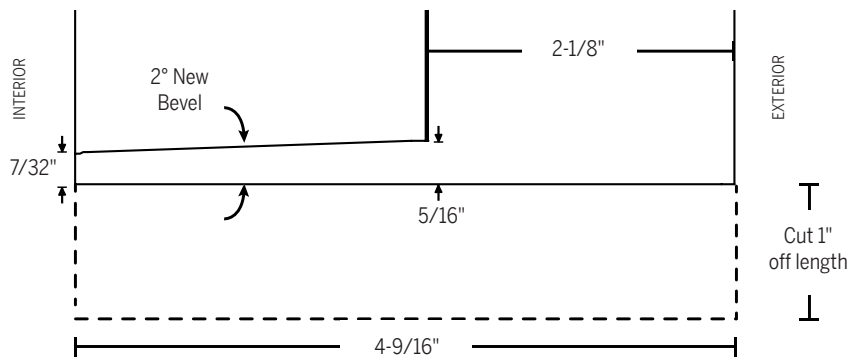

Screw Hole Pattern

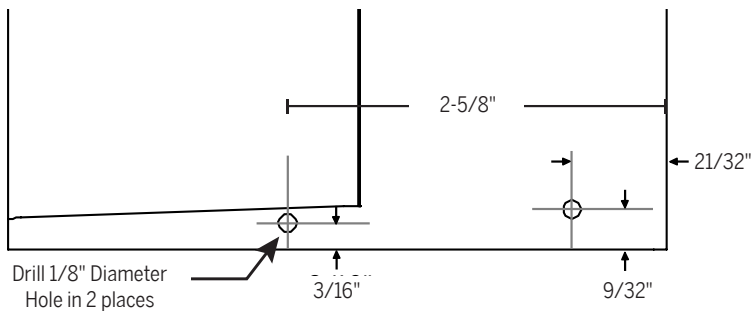

Jamb Modifications for 7-9/16" Outswing Sills

Jamb Modifications

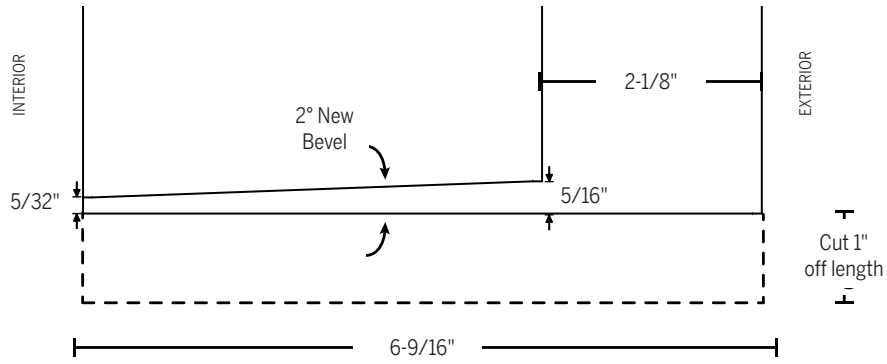

Screw Hole Pattern

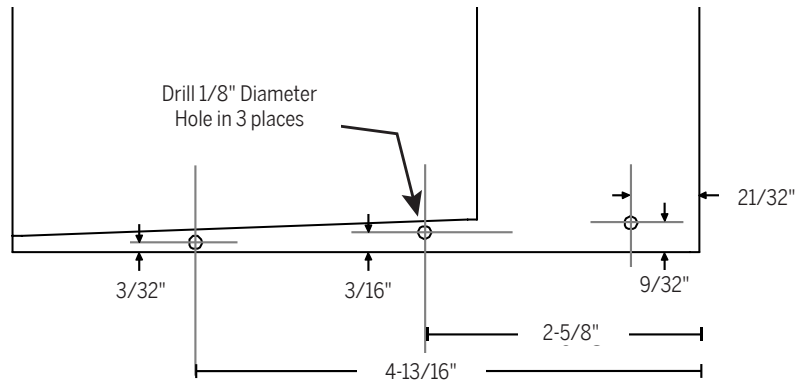

SADDLE ADA SILLS

Jamb Modifications for 5" Sills

Screw Hole Pattern

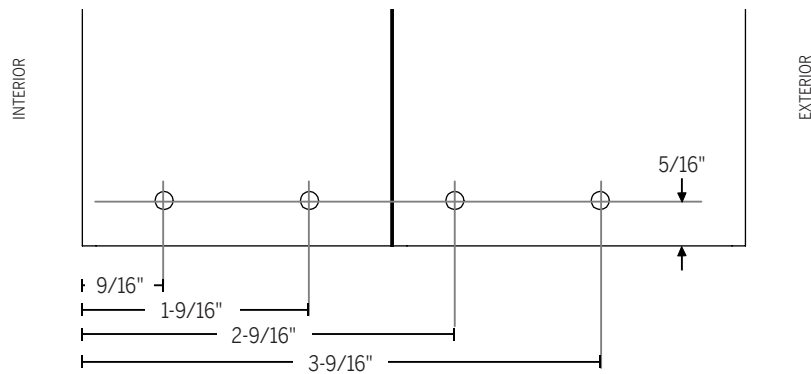

Jamb Modifications for 7" Sills

Screw Hole Pattern

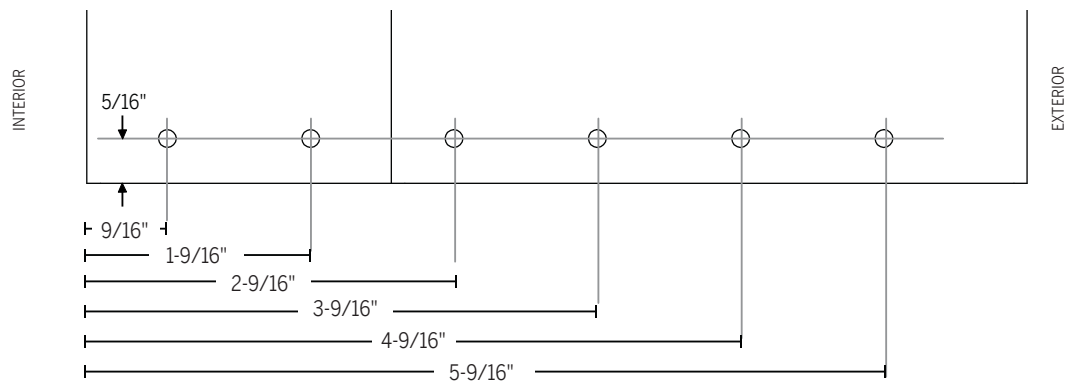

SILL AND JAMB ASSEMBLY INSTRUCTIONS

Screws Needed:

- #8 x 1-1/2" (2- 4, depending on sill width and swing)
- #6 x 1" (2) - For Optional Bracket

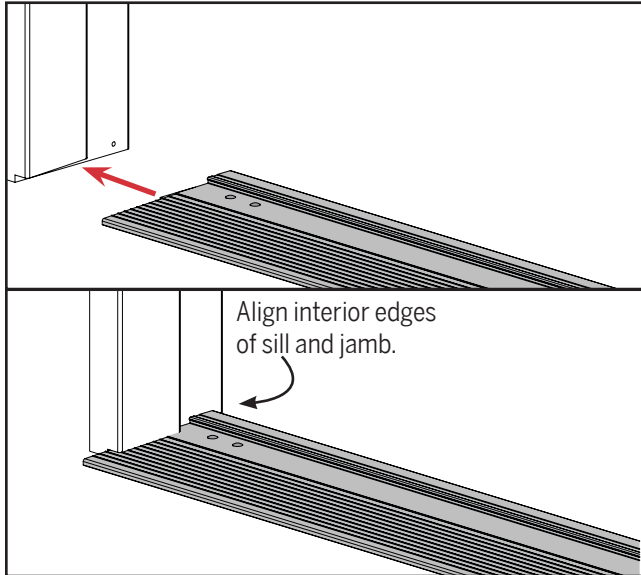

a. Place the sill flush against the predrilled jamb.

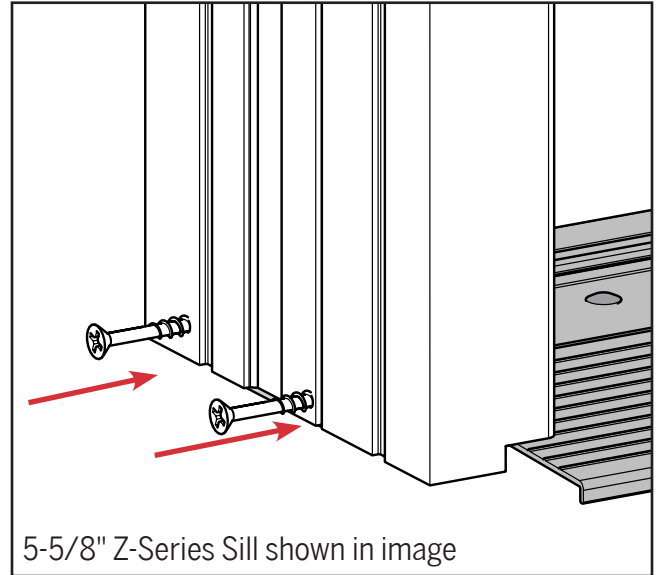

b. Drive and seat screws (#8 x 1-1/2") through the jamb, into the screw bosses.

IF BRACKET IS INSTALLED

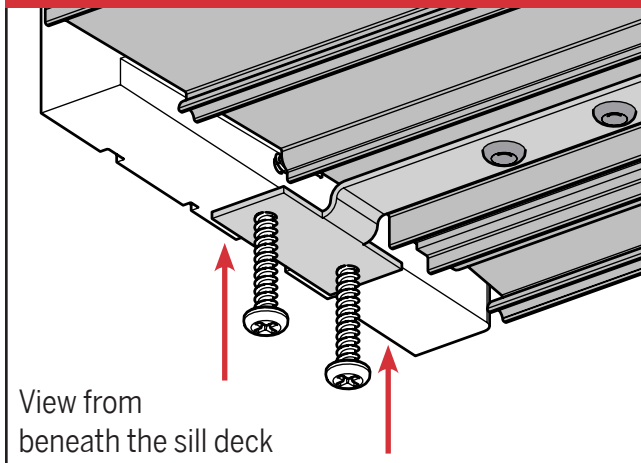

c. Drive and seat the bracket screws (#6 x 1") through the bracket, into the jamb.

Please Note:

- Brackets are not available on HCI or HCITILE sills due to the deck thickness. HCILITE sills can use brackets if it is straight cut.
- Brackets are not available on sills with C-Notches.