

ADA Sidelite Seat

Attachment and Conversion Instructions



8817 West Market Street
Colfax, NC 27235 | 800.334.2006
www.enduraproducts.com

ADA SIDELITE SEAT ATTACHMENT

INSWING

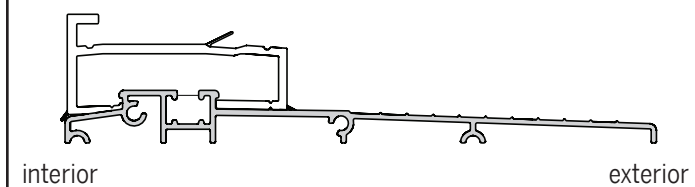

OUTSWING

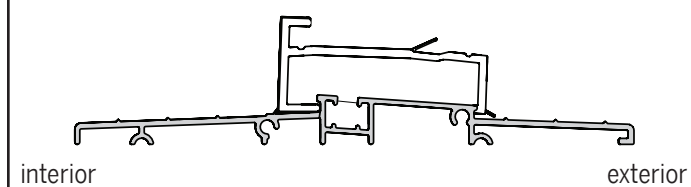

ADA SIDELITE SEAT INSWING TO OUTSWING CONVERSION

TOOLS REQUIRED:

- Cutting Tool

STEP 1: MODIFY THE SIDELITE SEAT

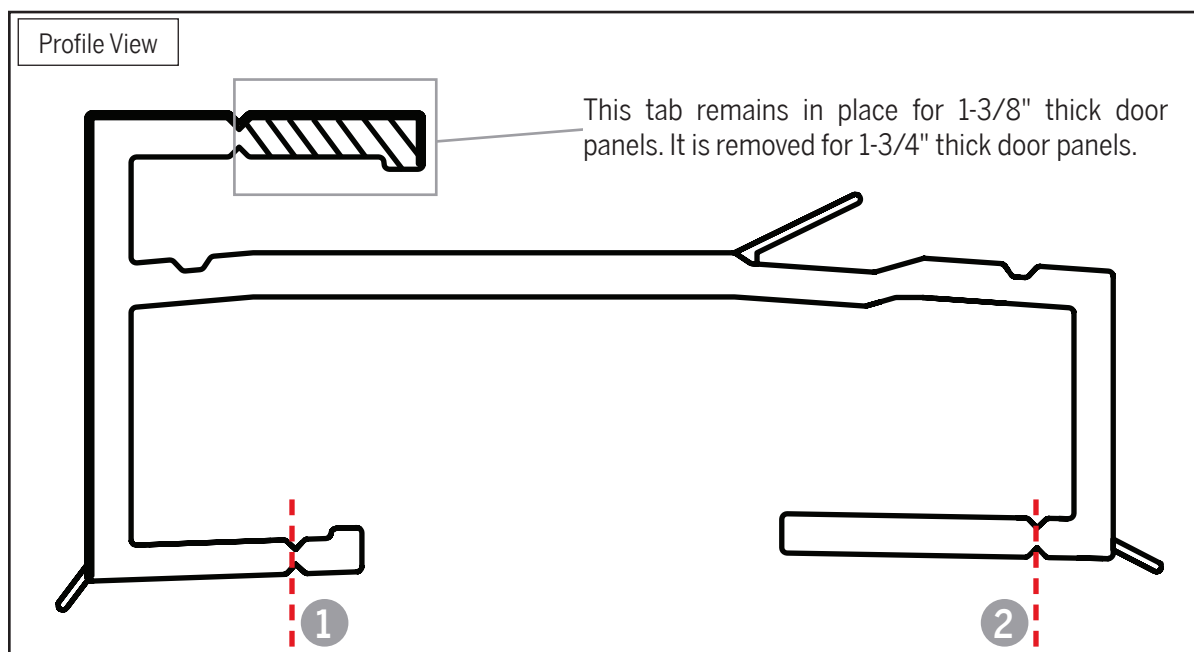

To convert the inswing sidelite seat into an outswing sidelite seat, identify the notches in the areas indicated in the image above at positions 1 and 2. Cut at these notches, along the length of the sidelite seat, and remove.

STEP 2: NOTCH THE ENDS (OUTSWING DOOR UNITS ONLY)

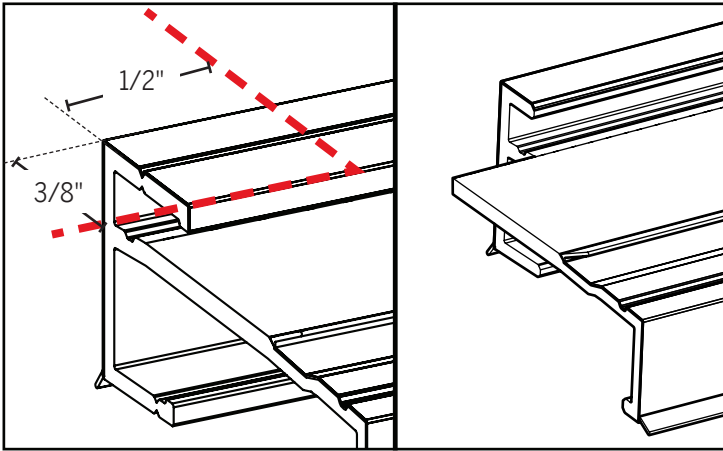

a. Notch the end of the sidelite seat by cutting the raised back and ensure a good fit against the jamb.

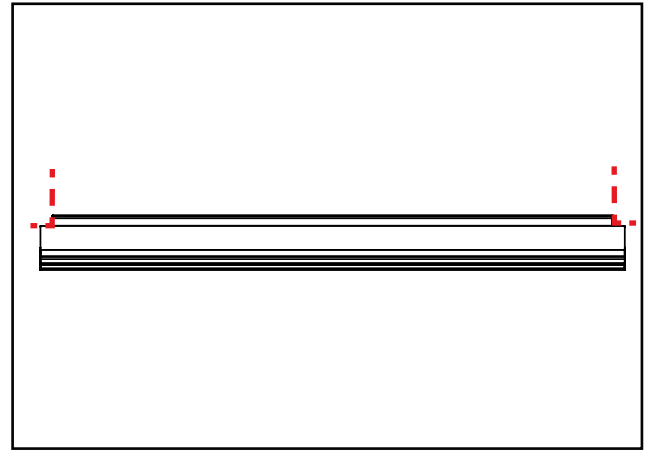

b. Make a similar cut, mirrored on the other end of the sidelite seat for the mull.

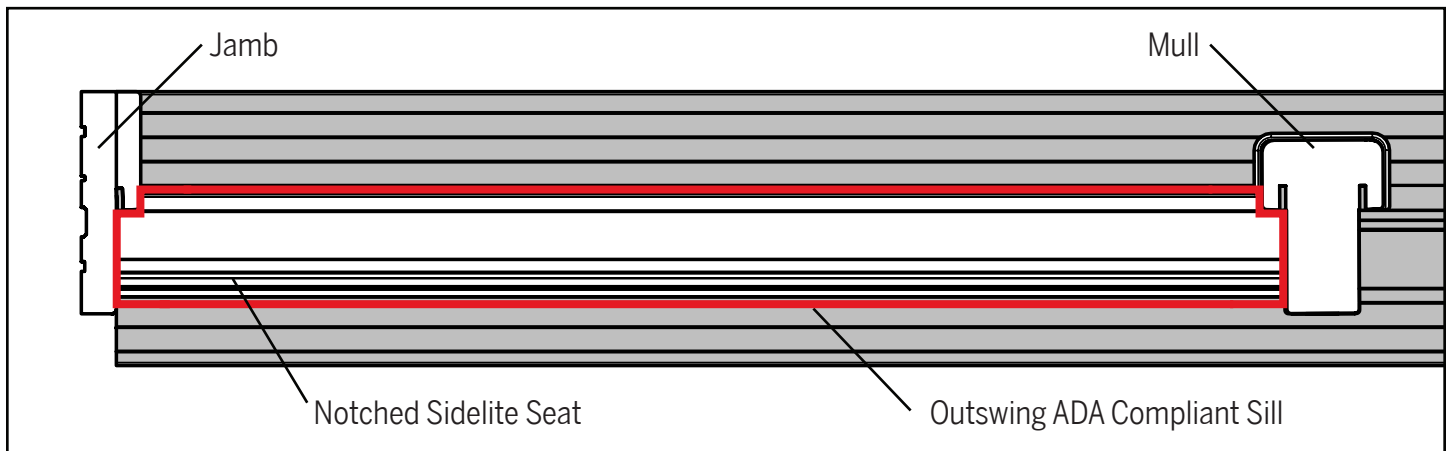

c. Install the notched sidelite seat between the mull and jamb.