

CERTIFIED POWERED BY ENDURA™ DOOR SYSTEM OWNERS MANUAL AND WARRANTY GUIDE



Congratulations on your purchase of a Certified Powered By Endura™ Door System incorporating components from Endura Products, Inc. Endura's components are designed to create performance and lasting value for your door system. This manual, and all instructions and warranties contained herein, is effective for all Certified Powered By Endura™ Door Systems assembled and installed on or after January 1, 2011 for use in the United States and Canada. For additional information, contact your Certified Powered By Endura™ dealer/distributor or refer to us at www.enduraproducts.com.



1.800.334.2006
www.enduraproducts.com

Your Certified Powered By Endura™ Door System: Certified Powered By Endura Door Systems are tested and certified to air and water performance levels particular to the door panels and configurations provided by Certified Powered By Endura Certified Prehangers. They incorporate the highest performance exterior door components from Endura Products, Inc. with door panels, door lites and hardware utilized by the Certified Powered By Endura Prehanger, and are backed by a Performance Warranty. Please utilize this guide, in addition to instructions for door panel finishing, maintenance and warranties, for ongoing performance of your Certified Powered By Endura Door System.

Certified Powered By Endura Components: Certified Powered By Endura Door Systems include the following components:

- Z-Series Composite Inswing or Bumper Outswing Sill
- PE650 Weatherstrip
- Simple Solution™ Corner Pad
- Dual Bulb Door Bottom
- Outswing Door Top (Outswing Only)
- Ultimate Astragal (Standard for French Door Units) or Multi-Point Astragal (optional)
- Continuous Sill, One Piece Mulls and Header for Sidelite and Hinged Patio Door Units
- Endura Approved Sill Pan* (optional) *See Web site for approved pans
- Endura or other approved Multi-Point Locking System (optional)
- FrameSaver Door Frames, Mullions, Brick Mould (optional)

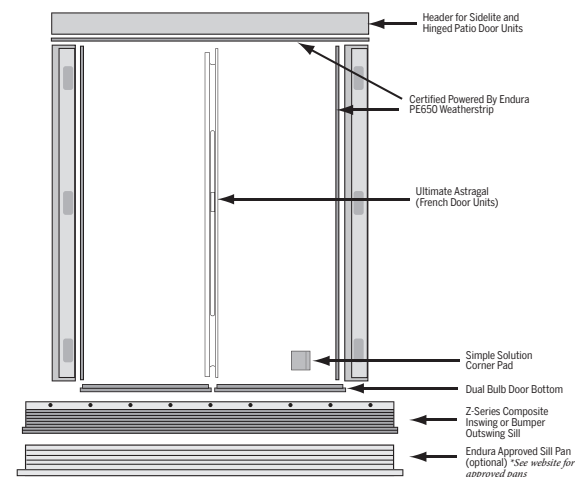

Certified Powered By Endura Door Unit Identification/Registration: Effective January 1, 2011, all Certified Powered By Endura Door Units can be identified by the metal Certified Powered By Endura Door Tag required to be applied by the certified Certified Powered By Endura Assembler. Please note the Serial Number on the Door Tag for use in registering your Certified Powered By Endura Door System and for reporting any Warranty issues.

Certified Powered By Endura Assembly and Installation: Your Certified Powered By Endura Door System was assembled and installed following specific instructions provided with the door unit. For questions regarding assembly and installation, please refer to our website: www.enduraproducts.com

Certified Powered By Endura Door Unit Care and Maintenance: Your Certified Powered By Endura Door Unit was designed to provide the maximum possible performance against air and water infiltration for the door panel and configuration selected. For continued performance over an extended period of time, and coverage under the Certified Powered By Endura Warranty, the following instructions must be followed:

Caulking and Resealing: Recaulking is required to maintain integrity of joints. At least one (1) time per year, inspect and recaulk the following with high quality exterior-grade caulk if caulk has split or is missing:

- Joints of the brickmould, frames, headers or mulls;
- Joints between the sill deck and frames and mullions
- Joints between the sill caps (active and inactive caps) and frame;
- Joints between the exterior sill and subsurface

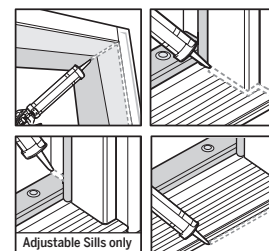

Door Sill Adjustment: Your Certified Powered By Endura™ Door System incorporates an all-composite Z-Series Sill from Endura. The following steps should be taken at least one (1) time per year to ensure proper sealing and prevention of air and water infiltration (NOT APPLICABLE TO ARTICULATING AND OUTSWING CAPS):

- As the house or door unit settles, contact between the sill and door bottom may become uneven. Adjust sill cap (inswing sills, except articulating) to meet door bottom as follows:
 - Remove Simple Solution™ Corner Pads;
 - Remove the cap plugs on top of sill cap;
 - Adjust the screws counter-clockwise to meet the desired cap height;
 - Replace the cap plugs
 - Caulk where cap meets jamb
 - Replace Simple Solution Corner Pads

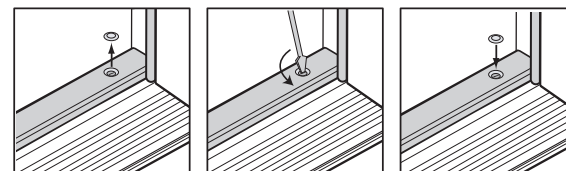

- In the case of a humped sill where adjustment of the cap will not resolve contact issues, further steps may be taken as follows:
 - Remove door from hinges and opening;
 - Remove brick mould or casing
 - Remove hinge long screws anchoring door to rough opening;
 - Shim jamb legs up to allow sill to straighten;
 - Replace long screws, door, brick mould;
 - Recaulk all joints
- Confirm sill cap length: In cases of extreme exposure, sill cap may not, over time, meet the overall length of the opening. Contact your Certified Powered By Endura distributor or dealer for a replacement cap. Replace as follows:
 - Remove existing corner pads (inswing only);
 - Remove existing cap: Using a standard slotted screwdriver, insert end of screwdriver under front (exterior) lip of cap at one end and pry upwards. Repeat step at middle and other end of cap until cap is lifted off. Remember to protect the deck of the sill with a soft cloth to prevent scratching;
 - Cut replacement cap to length of opening (See website for detail instructions);
 - Position cap over cap channel and, using moderate pressure, push cap down into channel;
 - Adjust cap to meet door bottom uniformly (adjustable cap only);
 - Reapply Simple Solution Corner Pads (inswing only)

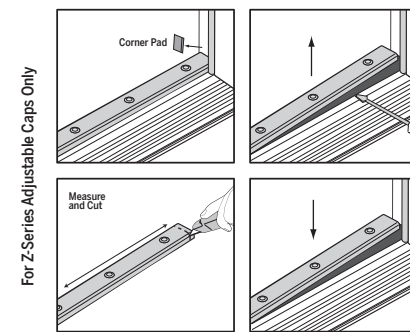

Door Bottom Wear and Replacement: Over time and operation of the door unit, door bottoms may tear, bunch or lose elasticity and memory. Door Bottoms must be checked one (1) time per year and replaced if necessary. Replacement door bottoms can be obtained from your Certified Powered By Endura Distributor or online at BetterDoor.com (Endura's retail partner), and replaced as follows:

- Remove door from hinges and opening;
- Remove old door bottom: Insert slotted screwdriver at one end of door bottom and remove along length of door; Clean and remove any remaining staples and caulk from bottom of door and kerfs of door;
- Cut replacement door bottom to length of door panel;
- Apply the caulk at each end of the door bottom and along the base of the exterior kerf leg (adjustable cap application only)
- Press replacement door bottom in place – staple to secure;
- Allow caulk to dry and reinstall door in opening.

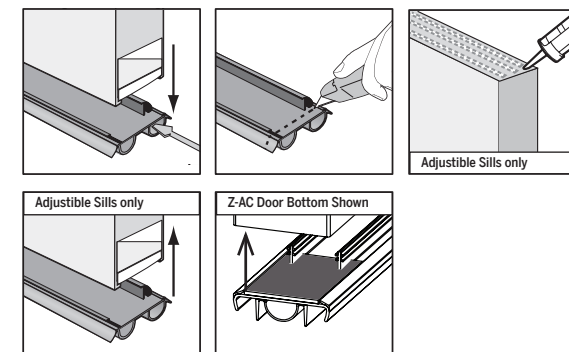

Weatherstrip Positioning, Wear and Replacement: PE650 Weatherstrip may be improperly installed or become torn or damaged. Check Weatherstrip upon installation and one (1) time a year for (i) tears in Weatherstrip; (ii) Weatherstrip not to length; (iii) Weatherstrip not meeting at intersection of frames and headers; or (iv) Weatherstrip bunched at bottom against door sill. Any of the above require repositioning or replacement of the weatherstrip as follows:

- Use only PE650 Weatherstrip for replacement. Any other weatherstrip will void the Certified Powered By Endura Warranty;
- Measure length of side frame/mull weatherstrip kerf from top of frame slot to sill deck – cut weatherstrip to indicated length and install in kerf. Take care to avoid bunching along length of kerf or at ends;
- Measure length of header kerf – cut weatherstrip to indicated length and install in kerf. Header weatherstrip must meet side jambs evenly at both sides.
- DO NOT PAINT WEATHERSTRIP. Paints, stains or varnishes contain solvents which, when coming into contact with materials used in weatherstripping, cause these materials to lose their flexible qualities, making them brittle and leading to a loss of sealing contact.

Weatherstrip Positioning - Continued

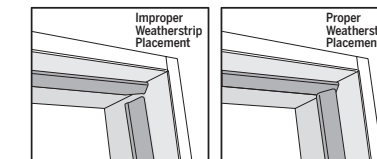

Simple Solution™ Corner Pad Positioning, Wear and Replacement: Corner Pads are an integral part of the Certified Powered By Endura™ Door System weathersealing. Damaged or incorrectly positioned corner pads can cause a loss of sealing. Check corner pads upon door installation and at least one (1) time a year for the following:

- Use only Simple Solution Corner Pads for installation or replacement. Use of any other corner pads will void the Certified Powered By Endura Warranty.
- Corner Pads should be applied ONLY AFTER (i) final painting; and (ii) sill cap adjustment. If door frame is repainted, Corner Pads should be removed and a new pair reapplied;
- After final sill cap adjustment (or upon replacement), position Simple Solution Corner Pad as follows:
 - Place bead of caulking at end of sill cap (adjustable sills only)
 - Remove the adhesive backing pad
 - The fin of the corner pad should be tucked under the weatherstrip, and aligned flush with the interior face of the jamb
 - The bottom of the Simple Solution Corner Pad should be flush with the cap of the sill for adjustable sills, or contacting the top of the Z-End Base™ for articulating sills;

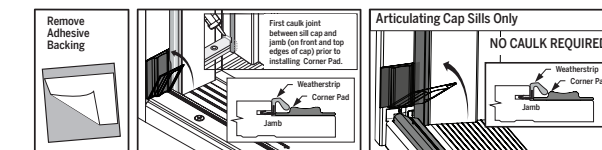

- Rotate Simple Solution Corner Pad in place

Ultimate Astragal: Endura's Ultimate Astragal is an integral part of Certified Powered By Endura French Door Units. To ensure proper performance of the Ultimate Astragal, check the following upon installation and one (1) time per year:

- Ensure proper margin between active and inactive doors when active door is closed – margin should be 1/8" maximum
 - If margins exceed 1/8", remove casing, doors from hinges and long hinge screws into rough opening. Shim behind frames at hinge points on both active and inactive doors to gain proper margin.
 - Replace long screws, doors and casing. Recaulk where necessary.
- Ensure header and sill flush bolt receivers are installed properly and flush bolt movement is for full range of operation;
 - Check that depth of holes for flush bolt receivers are drilled to proper depth – 1 - 3/8" for sill receiver, through header for upper flush bolt
 - Check that flush bolt receivers are installed and flush with sill cap and header surfaces
 - Check that flush bolts, when fully engaged, are in full contact with sill cap and header.

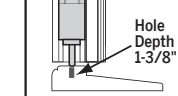
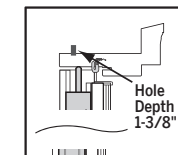
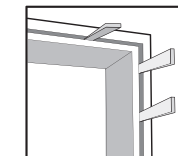
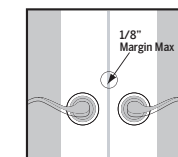

- Ensure proper compression of astragal weatherstrip when active door is closed;
 - If compression is not tight or apparent, loosen screws on strike and deadbolt plates on astragal and reposition inward to draw active door in tighter. Retighten screws.

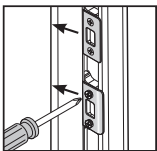

- If door unit contains Endura’s Wood Veneer Ultimate Astragal, exterior wood veneer should be finished with a stain and sealer or other finish appropriate for exterior applications. Finish must be applied to exterior wood surface initially prior to or during installation of door unit and should be checked one (1) time per year and refinished as necessary to prevent any deterioration of wood veneer.

Exterior Frame/Hardware Adjustments: Proper tight and consistent contact between the door panel and the weatherstrip is necessary for Certified Powered By Endura™ Door System performance to tested standards. Check the following upon installation and two (2) times per year:

- If door panel is sagging in the frame or margins are inconsistent:
 - Ensure that one long screw is properly installed in each hinge (two on the top hinge) through the frame into the rough opening
 - Ensure that frame and door are square. Check side frames, header and sill for level and measure diagonal distances from interior header corners to opposite jamb bottom. If not level or distances are not equal, loosen long hinge screws, remove door, remove interior casing (and exterior brick mould if necessary) and reshim to obtain level and square unit. Replace long screws, door and casing and caulk all joints thoroughly.

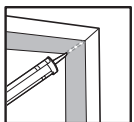
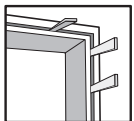
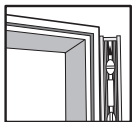

- If door panel is not meeting weatherstrip evenly or consistently when it closes:
 - Use a level to check that door is not warped. A warped door panel will need to be replaced by the dealer/distributor.
 - Check strike and deadbolt plate positioning; reposition towards the stop of the frame if required;
 - If door panel is not warped and repositioning of strike and deadbolt plates do not draw in door for full compression, check lock-side frame for alignment with panel. If frame is out of alignment, re-shim, re-adjust and re-nail frame so door meets the weatherstrip evenly from top to bottom.

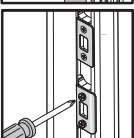
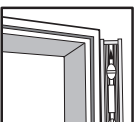

Flashing/Weatherproofing: Properly installed and maintained head flashing is required to protect the top surfaces of the door unit and prevent leaking around the door frame

- Following installation, check to ensure that sheet metal or other impervious head flashing is installed to serve as a moisture barrier above the brick mould, that a water resistant tape or seal has been installed over the head flashing, and that caulk has been applied around all joints between flashing, brick mould and other surfaces
- Visually inspect header flashing one (1) time per year for any damage, cracks in joints or other gaps in the moisture barrier. Repair or replace flashing as necessary. Recaulk all joints.

Flashing/Weatherproofing - Continued

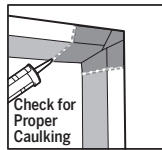
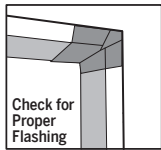

Exterior Frame Painting & Refinishing: Repainting every 1 to 5 years will be required, depending upon weather exposure and the paint manufacturer’s recommendations. Any signs of blistering, peeling or cracking the finish should be immediately repaired to protect the wood underneath. Failure to properly protect the frame with a top coat will result in wood damage, including frame finger joint damage

- Thoroughly dry surfaces, making them free of dust, dirt, oil, grease, wax, chalk and other contaminants.
- A high quality exterior latex paint, preferably a 100% acrylic-based product, should be used as a finish coat.
- Follow the paint manufacturer’s recommendations on thinning, application techniques, re-coat and dry times.
- In general, paint should be applied when both the surface and air temperature is between 50 and 90 degrees F. Relative humidity should be below 85%.

CERTIFIED POWERED BY ENDURA™ DOOR SYSTEM LIMITED WARRANTY

This CERTIFIED POWERED BY ENDURA WARRANTY (“Warranty”), extended by Endura Products, Inc. (“Endura”), provides that, subject to the limitations and exclusions below, and for the duration of the applicable Warranty Period (i) the Endura Components contained therein (and as detailed in Section 1 below) will be free from non-conformities in materials and workmanship and (ii) provides for additional payment by Endura of up to a maximum of \$1,500 reimbursement if the Certified Powered By Endura door system fails to perform (on the basis of water infiltration) to the certified performance criteria of that system. This Warranty applies to Certified Powered By Endura Certified Door Systems purchased and installed on or after December 1, 2010.

1. Components Incorporated in Certified Powered By Endura System this Warranty Covers: Each Door System covered under the Certified Powered By Endura Warranty shall incorporate Endura approved and supplied components matching the specifications and dimensions utilized in tested and certified assemblies on which the Door System rating is based. Any change in or substitution of components specified below will void the Certified Powered By Endura Warranty on the Door System. Specific components supplied by Endura, utilized in Certified Powered By Endura Certified Testing, and applicable to the use and warranty of the Certified Powered By Endura Door Systems include:

- Composite Z-Series High Dam (1 3/8”) Adjustable Inswing Door Sill or Composite Z-Series High Dam Bumper Outswing Sill;
- Simple Solution™ Corner Pads, properly installed;
- PE650 or other Endura tested and approved Certified Powered By Endura Weatherstrip;
- Endura Dual bulb door bottom applicable to door construction/type and Certified Powered By Endura Outswing Door Top (outswing only);
- Endura Ultimate, Ultimate 3-Point Compatible or Multi-Point Astragal on double door (French) systems;
- Frame components (excluding side frames) for continuous sidelite, hinged patio and additional multiple panel configurations;
- Endura multi-point lock system or other certified tested and approved multi-point lock system (optional);
- Endura sill pan installed in accordance with published Certified Powered By Endura instructions (optional)

Endura reserves the right to, and will from time to time, modify, make improvements to, substitute for or otherwise add components to Certified Powered By Endura requirements based upon improvements in product and/or Certified Powered By Endura Door System performance. Except as provided by Endura, wood components, including but not limited to door frames, mull posts, brick mould and mull casing are not covered by this Warranty. Other Door System components, including but not limited to door slabs (and any applied or inserted panels), hinges, glass lites, wood grilles or other hardware are not covered by this Warranty.

2. Certified Powered By Endura™ Warranty Period: Lifetime non-transferable Warranty, applicable to the original homeowner, from the date the Certified Powered By Endura Door System was purchased from an authorized dealer, except in commercial or multi-unit residential applications in which the Warranty shall be limited to 5 years from the date the Certified Powered By Endura Door System was purchased from an authorized dealer and which shall be transferable during and for any balance of the original 5 year period.

3. Certified Powered By Endura Unit Identification: Each Certified Powered By Endura Door System is identified by a non-removable tag. Removal of the Certified Powered By Endura Door Tag by any third party installer or residential owner will void the Certified Powered By Endura Warranty on the individual Door unit.

4. Certified Powered By Endura Warranty Reimbursement: If the Certified Powered By Endura Door System (a) includes all of the applicable components referenced above, (b) has been properly assembled and installed following recommended Certified Powered By Endura procedures, (c) has not been subjected to changes in rough opening dimensions and stability (i.e. plumb and square) and (d) has been properly maintained by the Warranty Holder, and (e) the product (or components) fail to perform to the certified and published levels of air and water infiltration applicable to the Door System during the Warranty Period solely due to non-conformities in the product as warranted, and (f) Endura is notified using Certified Powered By Endura Warranty Claims Procedures, then Endura will:

- Provide a factory-authorized repair or replacement component, at no cost to the Warranty Holder OR at Endura’s option, provide replacement component(s) to the Warranty Holder or Endura’s designated dealer (assembly and installation labor is not included), OR at Endura’s option, refund the Warranty Holder’s purchase price (the lesser of the original component purchase price or the original catalogue price), in lieu of repairing or replacing the components as provided; AND
- Pay to Warranty Holder either, selected at Endura’s option, (a) the fair market value of any other property damaged due to water infiltration caused solely as a result of such nonconforming component or Certified Powered By Endura Door System; or (b) Warranty Holder’s actual reasonable costs to repair or replace such damaged property or install replacement component(s) supplied by Endura as provided above, in either case, up to the maximum amount listed below for the specified Certified Powered By Endura Door System. Warranty Holder must have taken reasonable steps in a timely manner to mitigate any resulting property damage, provide evidence of costs or damages incurred as requested by Endura, and submit a claim within 30 days as provided below. If the fair market value of any damaged property is unclear, Endura may engage a third party inspector or appraiser for assistance.

CERTIFIED POWERED BY ENDURA WARRANTY REIMBURSEMENT GUIDELINES ^(a)				
Components Utilized	With Sill Pan ^(b)		Without Sill Pan	
	With Multi-Point Lock ^(c)	Without Multi-Point	With Multi-Point Lock ^(c)	Without Multi-Point
Single Door Multiple Panel Door ^(d)	\$500 \$1,500	\$350 \$1,000	\$275 \$750	\$200 \$500
FrameSaver Single/French Door CSL/Hinged Patio	Add \$75 \$150	Add \$75 \$150	Add \$75 \$150	Add \$75 \$150
NAMI Certified Assembly ^(e)	Add \$100	Add \$100	Add \$100	Add \$100

- \$ Amount represents maximum limit on Certified Powered By Endura Warranty Claims for Door units/components Referenced;
- Must be a SureSill sill pan or sill pan approved by Endura and installed following Certified Powered By Endura procedures;
- Must be a 3-Point Lock system tested by Endura with such door panel and approved by Endura;
- Multiple panel units include French Door, Continuous Sidelite and Hinged Patio doors;
- If the Certified Powered By Endura Door System is assembled by a third party NAMI certified distributor/dealer and bears the original NAMI certified assembly label (check door-hinge edge), the Product is a “NAMI Certified Assembly”.

5. Warranty Exclusions: The Certified Powered By Endura™ Warranty does not cover the following:

- FAILURE OF THE CERTIFIED POWERED BY ENDURA DOOR SYSTEM DUE TO CHANGES TO OR USE OF COMPONENTS WHICH DO NOT ADHERE TO THE SPECIFICATIONS PROVIDED TO SUCH THIRD PARTIES BY ENDURA and which have not been utilized in certified Certified Powered By Endura testing for such door system;
- FAILURE OF THE CERTIFIED POWERED BY ENDURA DOOR SYSTEM DUE TO USE OF COMPONENTS WHICH ARE NOT GENUINE ENDURA COMPONENTS (as outlined in Section 1 above) and which have not been utilized in certified Certified Powered By Endura testing for such door system;
- FAILURE OF THE CERTIFIED POWERED BY ENDURA DOOR SYSTEM DUE TO IMPROPER ASSEMBLY BY THIRD PARTIES, inconsistent with recommendations and written instructions provided by Endura or generally available in Endura’s Product Manuals as amended time to time by bulletins or other written communications on Endura’s website www.enduraproducts.com; this includes failure in performance of the Certified Powered By Endura Door Unit due to separation of the frame and sill components.
- FAILURE OF THE CERTIFIED POWERED BY ENDURA DOOR SYSTEM DUE TO IMPROPER INSTALLATION BY A BUILDER, REMODELER OR OTHER PERSON OR ENTITY THAT INSTALLS, OR HANDLES THE PRODUCT OTHER THAN ENDURA PRODUCTS, INC., inconsistent with recommendations and written instructions provided by Endura or generally available in Endura’s Product Manuals as amended time to time by bulletins or other written communications on Endura’s website www.enduraproducts.com;
- Failure of the Certified Powered By Endura Door System due to uses or exposure to conditions for which its use and Warranty was not intended, such conditions to expressly include failure due to mechanically or other non-weather related driven water, utilization of inswing door units and components for outswing applications, further machining of or on the door panel, frame components after pre-hanging, or any other modifications or uses not specified in the Certified Powered By Endura pre-hanging or installation instructions;
- Failure of the Certified Powered By Endura Door System due to failure of non-Endura supplied components (i.e. door glass assembly, door panel or hardware failure);
- Rotting, splitting, warping or swelling of a frame system, unless the frame system is a genuine FrameSaver rot resistant component part. Use of a non-FrameSaver frame system by the Warranty Holder (or its builder, installer, contractor, or other agent) will not automatically void this Warranty, HOWEVER this warranty will not apply to Certified Powered By Endura Door System non-conformities or damages attributable to or arising from the rotting, splitting, warping, swelling or any other condition of a third party frame product;
- Removal, reinstallation or alternation of a Certified Powered By Endura Door System or any of its components following original installation except in connection with proper and timely maintenance of components which incur normal wear and tear, such as the weatherstripping, door bottom and corner seals, in which case Warranty shall only apply if such components are replaced with the applicable Certified Powered By Endura components;
- Failure of the Warranty Holder to provide timely normal maintenance of the Certified Powered By Endura Door System;
- Failure to operate the Certified Powered By Endura Door System in accordance with its instructions, including, without limitation, fully engaging the entire Endura approved locking system whenever the Certified Powered By Endura Door System is closed;
- Failure of the Warranty Holder to timely take reasonable actions to mitigate any property damage;
- Labor, services and materials to paint, stain, or refinish applied to or adjacent to the Certified Powered By Endura Door System, or other carpentry or the addition of non-Certified Powered By Endura door system componentry, or other work undertaken that is intended to remedy a Certified Powered By Endura Warranty complaint, that is not part of the Certified Powered By Endura Door System, without the prior authorization of Endura Products, and which itself or in addition to any other property damage, exceeds the Maximum Certified Powered By Endura Coverage Warranty Limit;

(xiii) Failure to file a claim for alleged damages promptly a during the Warranty Period;

(xiv) Non-application of the Certified Powered By Endura™ Warranty due to any of its stated terms and provisions.

6. Claims: Claims under this Warranty must be initiated within 30 days following Warranty Holder’s earliest awareness of a potential issue for which recovery arises under this Warranty. Any claims must follow specified procedures for any Claims arising from Door Systems which do not meet certified performance levels upon and subsequent to installation. Failure to follow Certified Powered By Endura Warranty Claim Procedures (either timing or procedures) may void the Certified Powered By Endura Warranty on the individual door unit. To obtain help under this Warranty, or to initiate a claim, Warranty Holder should contact Endura Products, Inc. in writing at 8817 West Market St., Colfax, NC 27235 “Attn – Warranty Claims,” or call (800) 334-2006 or by email at warrantyclaims@enduraproducts.com. The Certified Powered By Endura Warranty Claim Procedure will not be initiated until all of the following information is received:

- Homeowner/Warranty Holder Name, Complete Street Address, Email Address, Daytime Telephone Number
- Certified Powered By Endura Door Tag Number (Certified Powered By Endura Door Tag is attached to the frame of the door system near the top hinge)
- Date of Home Purchase
- Name of Original Home Builder (if known)
- Description of Warranty-Related Complaint and Associated Damage
- Attached Photos of Warranty-Related Complaint and Associated Damage

Endura must receive this Warranty Claim notification within 30 days following the Warranty Holder’s earliest awareness of a potential issue for which recovery arises under this Warranty. Following receipt of this information, Endura Products will (a) provide a copy of the *Certified Powered By Endura Door System Owners Manual and Warranty Guide* to the Warranty Holder, (b) notify the Warranty Holder that compliance with the “Certified Powered By Endura Unit Care and Maintenance” procedures outlined within the *Certified Powered By Endura Door System Owners Manual and Warranty Guide* must be performed and up-to-date as a prerequisite to continuing the claim process, and (c) initiate and facilitate the Certified Powered By Endura Warranty Claim Procedure. However, the Warranty Holder **must** perform door unit maintenance and reassess the complaint before Endura proceeds with the Certified Powered By Endura Warranty Claim Procedure. Select replacement parts needed for door unit maintenance are available directly from Endura Products at www.enduraproducts.com/parts. In addition, Endura recommends that the Warranty Holder contact their builder if assistance is required to perform door unit maintenance and/or to assess other potential remedies to the complaint.

7. General Conditions and Exclusions: The Warranty set forth in this document is the only express warranty (whether written or oral) applicable to Certified Powered By Endura Door Systems and no one is authorized to modify or expand this Warranty. Some states do not allow the exclusion or limitation of incidental or consequential damages, so the above limitations or exclusions may not apply to the Warranty Holder. This limited Warranty provides specific legal rights, but Warranty Holder may have other rights that apply from state to state. If this limited Warranty is deemed to have failed its essential purpose, in no event will Seller’s entire liability exceed the lesser of the Certified Powered By Endura Door System’s or the non-conforming components purchase price.