

# Ultimate Push Button Astragal

## Reversibility Instructions



8817 West Market Street  
Colfax, NC 27235 | 800.334.2006  
www.enduraproducts.com

### Tools Required:

- Chop Saw
- Tape Measure
- Pencil/Marker

### Kit Includes:

- Upper and Lower Trim Caps
- Tail Caps (2)
- Back Pad

### Notes:

- Reverse astragals before cutting them down.

## STEP 1: REVERSE THE ASTRAGAL

**a. Remove astragal components:** Remove the two orange securing pins from the upper bolt sleeve and slide the bolt out of the astragal. Remove upper trim cap and tail cap if present. Remove the orange securing pin from the lower bolt and slide the bolt out of the astragal. Remove the lower trim cap.

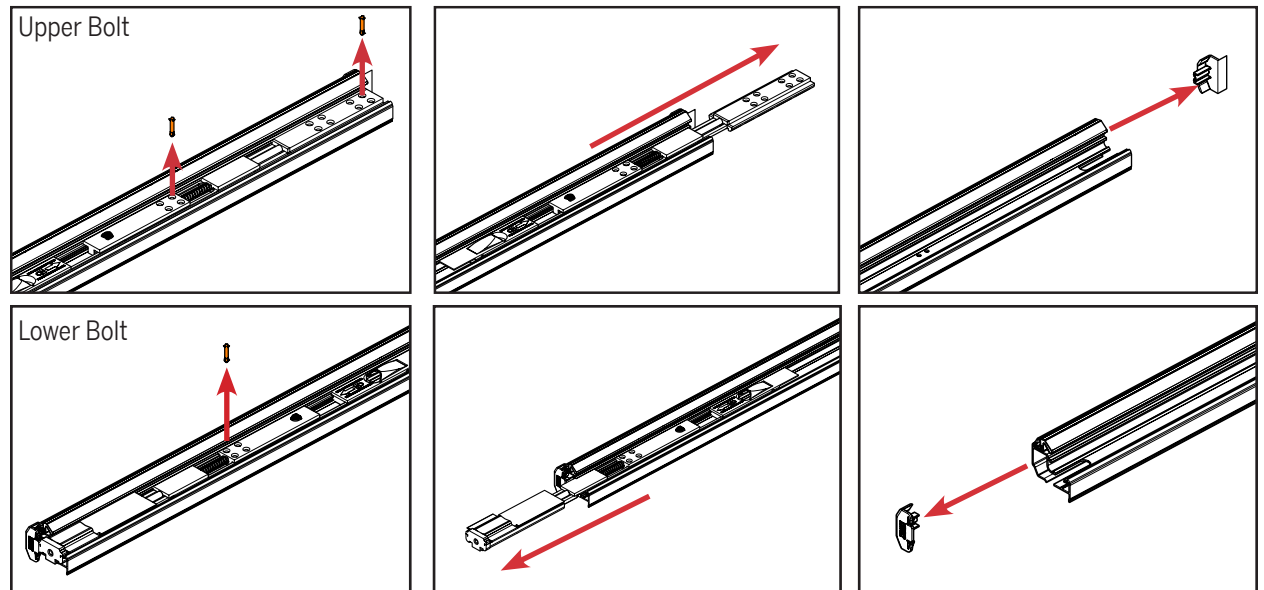

**b. Reverse the astragal:** Rotate the astragal so the upper and lower ends are reversed.

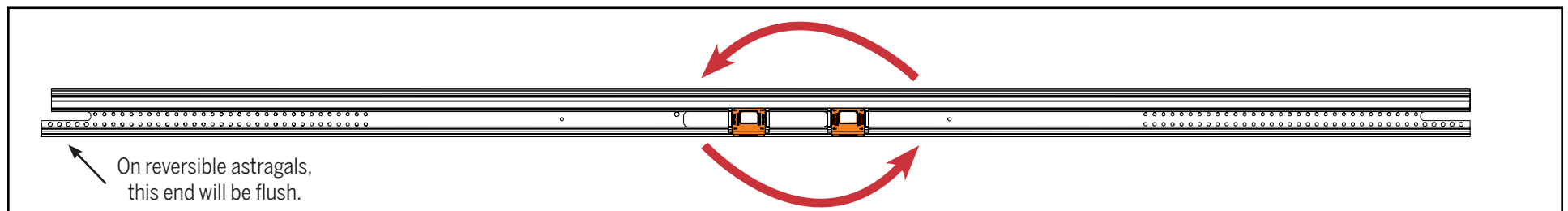

## STEP 2: CUT THE ASTRAGAL BODY FLUSH - NON-REVERSIBLE ASTRAGALS ONLY

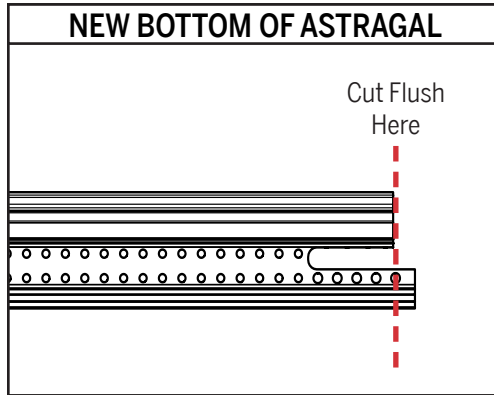

If you ordered a reversible astragal, you will not need to perform this step, as this end of the astragal will already be flush.

a. Using a chop saw, cut the **narrow side** of the astragal, so it is flush with the wide side.

## STEP 3: REINSTALL THE UPPER BOLT

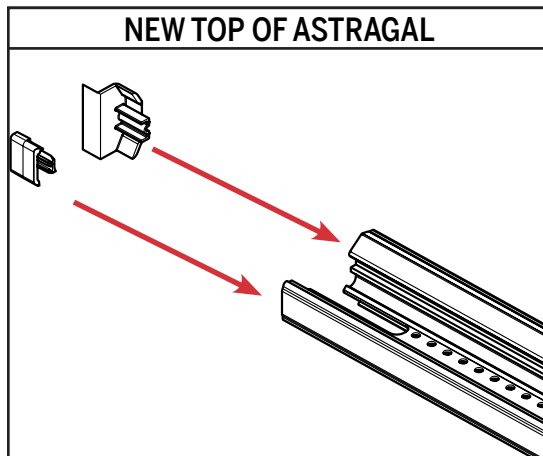

a. On what is now the top of the astragal, install the upper trim cap on the **wide side** and a tail cap on the **narrow side**.

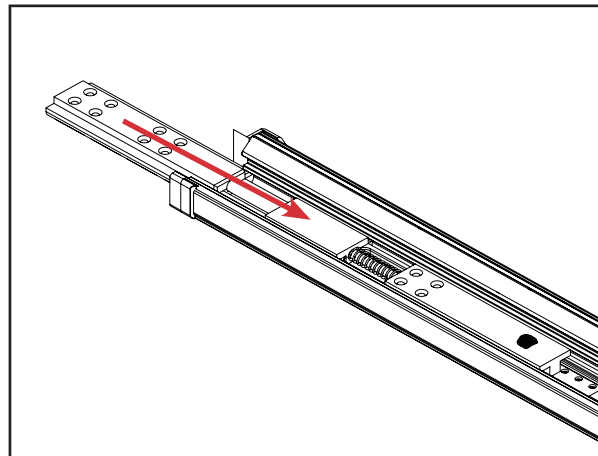

b. Return the **retracted** upper bolt by sliding it back into the astragal body until the end of the bolt sleeve is flush with the end of the astragal. If a tail cap is present, the bolt should be flush with the tail cap.

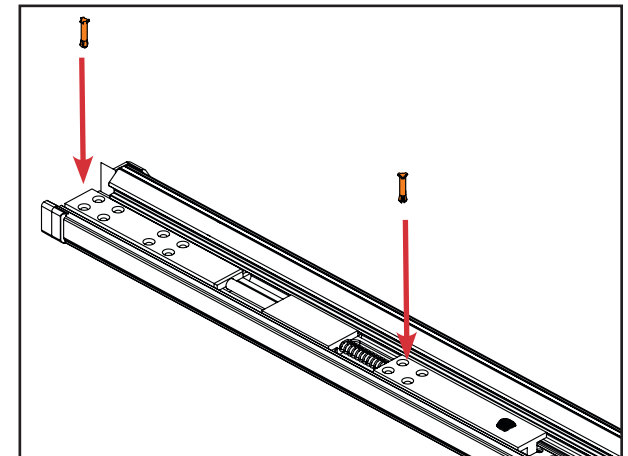

c. Insert the two orange securing pins into the bolt in the holes that align with the holes in the astragal body. (See below if holes are not aligned.)

## STEP 3 (CONT.): REINSTALL THE UPPER BOLT

To align screw holes in the bolt:

\* Body is darkened to show contrast.

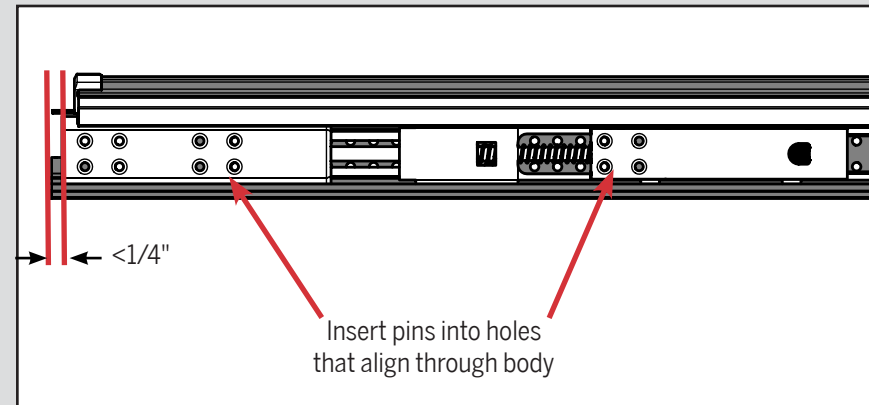
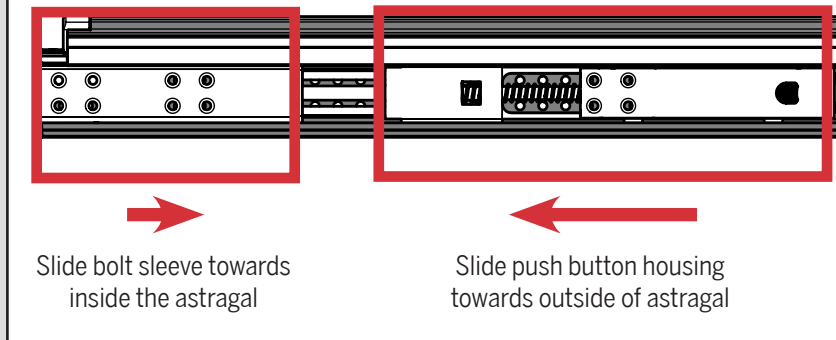

If the holes on the bolt do not align with the holes in the astragal body, adjust the location of the bolt sleeve and/or the push button housing to align the holes and then insert the orange securing pins. The bolt sleeve may be up to 1/4" inset from the end of the astragal.

## STEP 4: REINSTALL THE LOWER BOLT

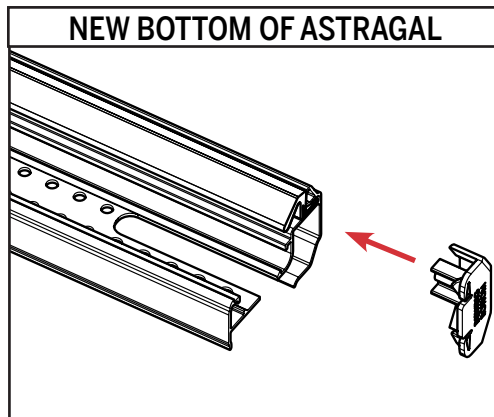

a. Reinstall the lower trim cap on to the astragal.

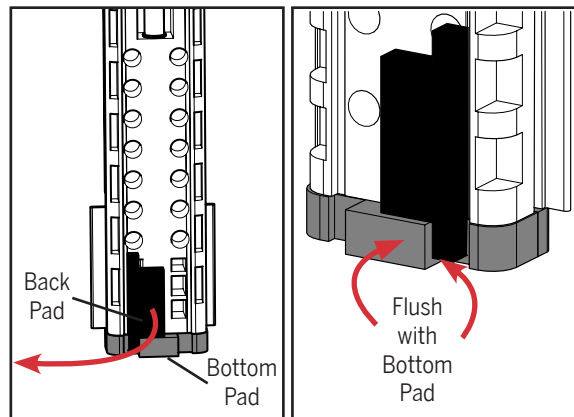

b. Before replacing the lower bolt, remove the existing back pad and place a new one mirroring the original pad.

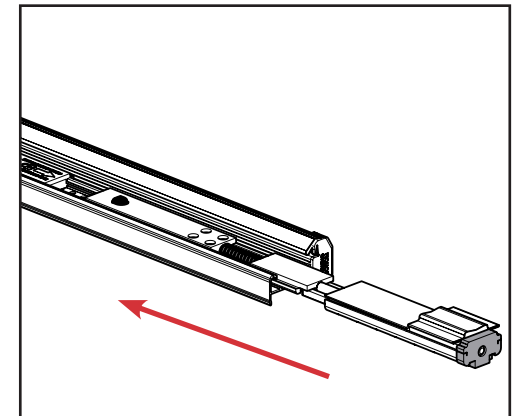

c. With the bolt in the unlocked position, slide the lower bolt back into the astragal.

 Do not remove or damage the bottom pad.

## STEP 4 (CONT.): REINSTALL THE LOWER BOLT

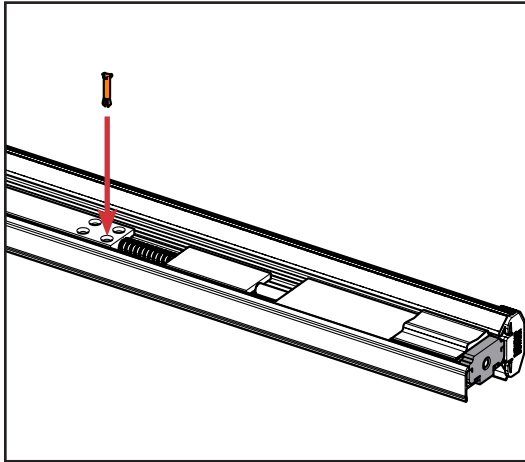

**d.** Insert the orange securing pin into the hole on the bolt sleeve that aligns with the hole in the astragal body. If holes do not align, see gray box on Page 3 to align holes.

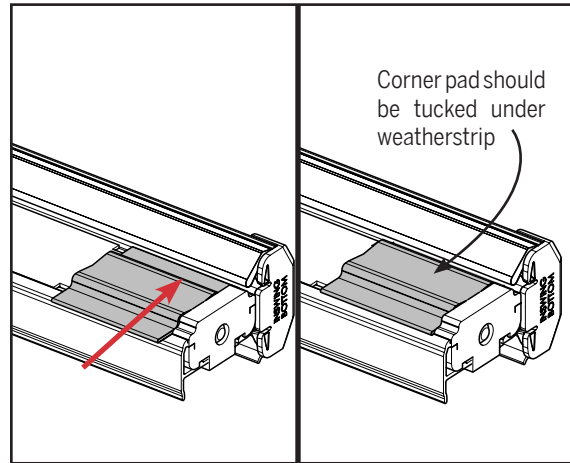

**e.** Once the lower bolt is installed, realign the Simple Solution Corner Pad under the weatherstrip.

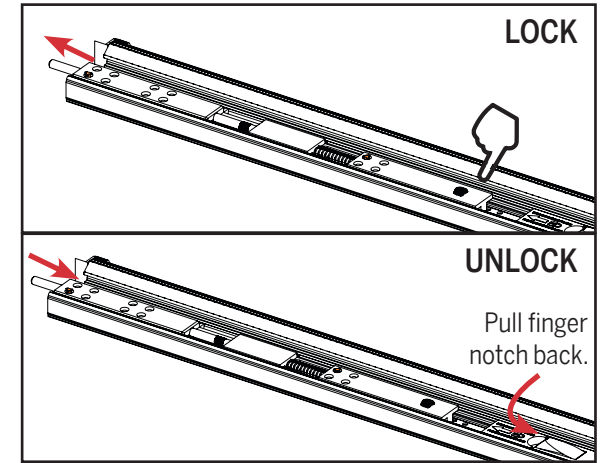

**f.** Confirm proper bolt operation by pushing the black button to engage the bolt and pulling back the finger notch to retract it.

## STEP 5: REINSTALL THE TRIM STRIP

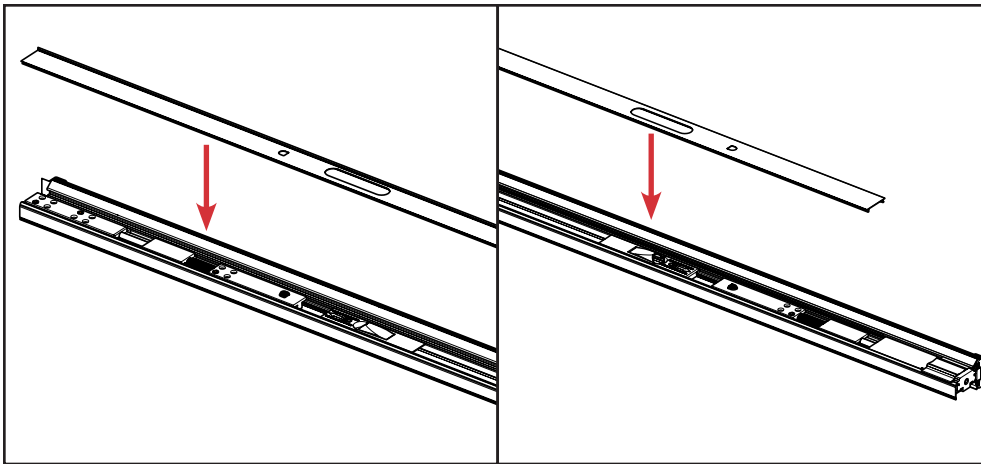

**a.** Reinstall the trim strip onto the astragal. The trim strip with the larger space between the notch and edge will be for the top of the astragal.