

Ultimate Push Button Astragal

Cut Down Instructions



8817 West Market Street
Colfax, NC 27235 | 800.334.2006
www.enduraproducts.com

Tools Required:

- Pencil/Marker
- Tape Measure
- Chop Saw

Notes:

- All cuts should be from the **top of the astragal**.
- Ultimate Push Button Astragals can be cut down a maximum of 7".

Optional Parts:



Tail Cap

STEP 1: INITIAL PREPARATION

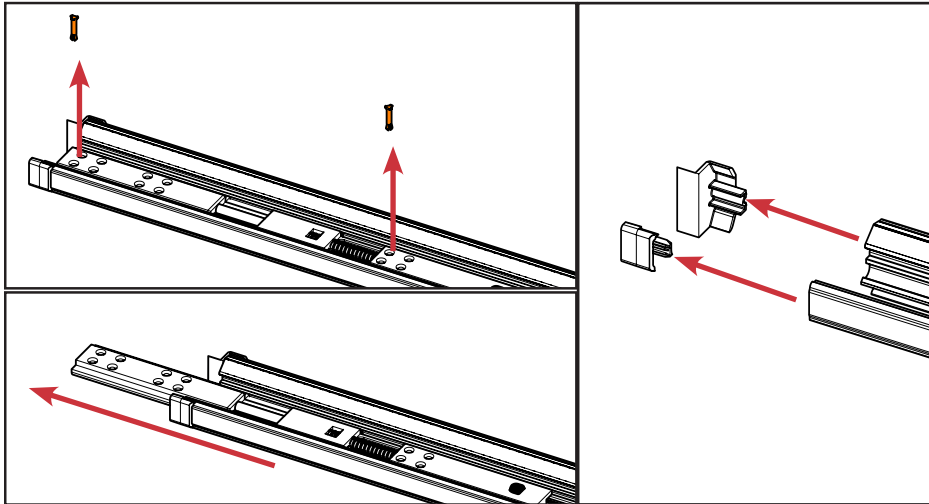

a. Remove components: Remove the two orange securing pins on the upper bolt and slide the bolt out of the astragal. Remove the upper trim cap and tail cap, if present, and set aside for reinstallation.

 **Ensure the upper bolt is in the unlocked position before removing.**

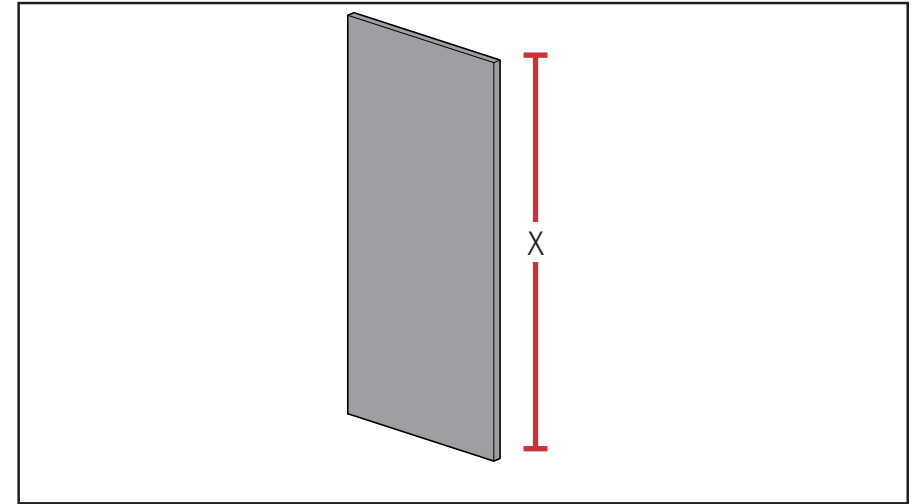

b. Measure the length of the door panel: Measure and note the height of the door panel (X).

STEP 2: CUT ASTRAGAL TO SIZE

IF YOU **DO** HAVE A TAIL CAP AVAILABLE:



a. Starting at the **bottom** of the astragal and measuring along the **wide side**, measure and mark (X- 9/16"). Cut the astragal flush at this location.

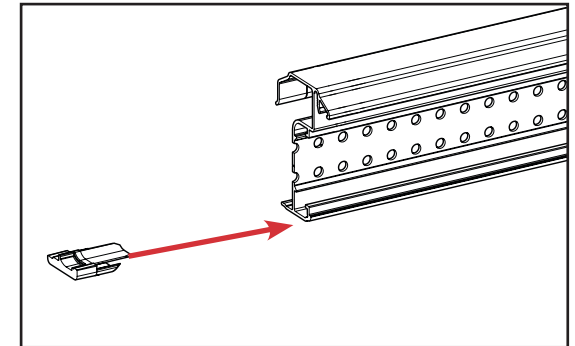

b. Insert the tail cap onto the **narrow side** of the astragal body. You may receive two tail caps, but only one will fit.

IF YOU **DO NOT** HAVE A TAIL CAP AVAILABLE:

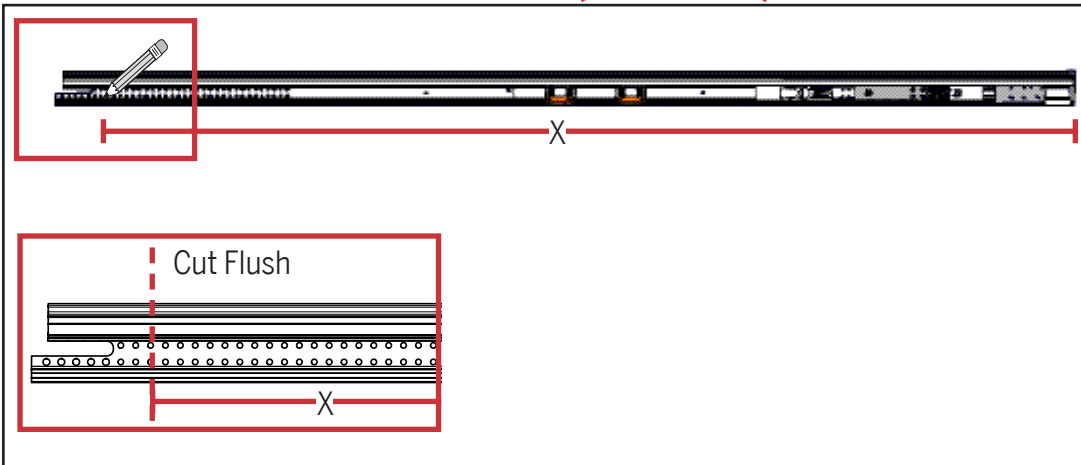

a. Starting at the **bottom** of the astragal and measuring along the **narrow side**, measure and mark (X) on the astragal. Cut the astragal flush at this location.

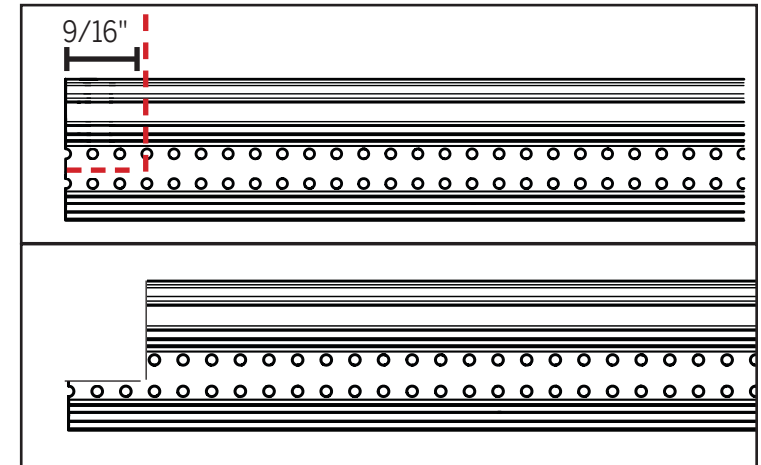

b. To notch the astragal measure 9/16" from the cut end of the astragal. Using a chop saw, cut at this point, until the space between the rows of holes in the astragal body. **Do not cut it flush.**

STEP 3: REINSTALL THE UPPER BOLT

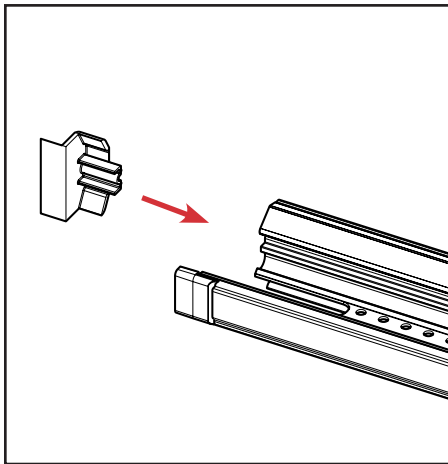

a. Reinstall the trim cap on the wide side of the astragal.

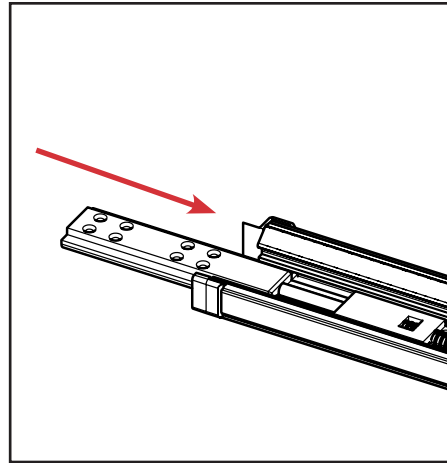

b Return the upper bolt by sliding back into the astragal body until the end of the bolt sleeve is flush with the end of the astragal.

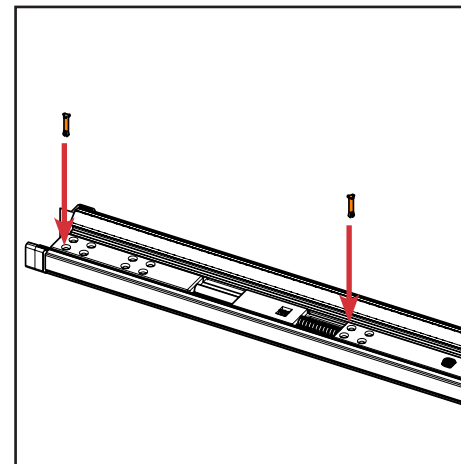

c. Insert the two orange securing pins into the bolt in the holes that align with the holes in the astragal body. (See below if holes are not aligned.)

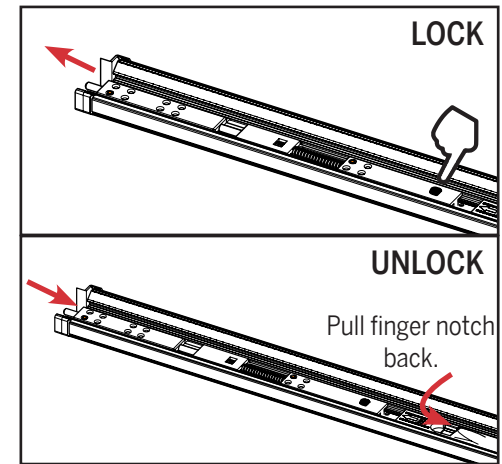

d. Confirm proper bolt operation by pushing the black button to engage the bolt and pulling back with the finger notch to retract it.

Following cut down, the holes on the bolt **may not line up exactly** with holes in the astragal body.

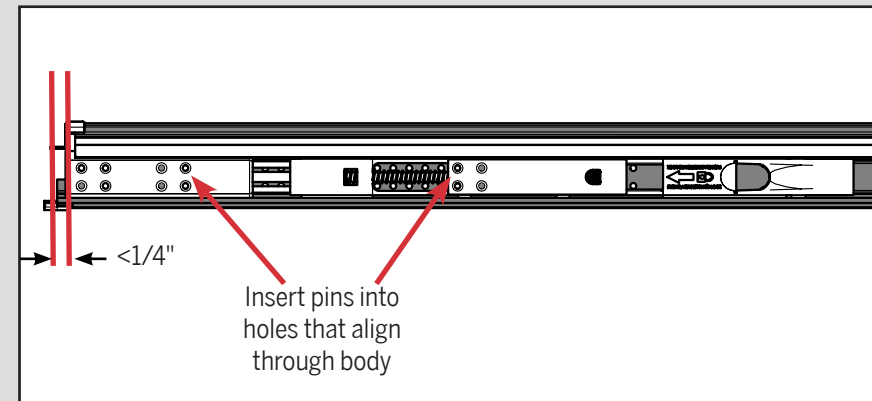
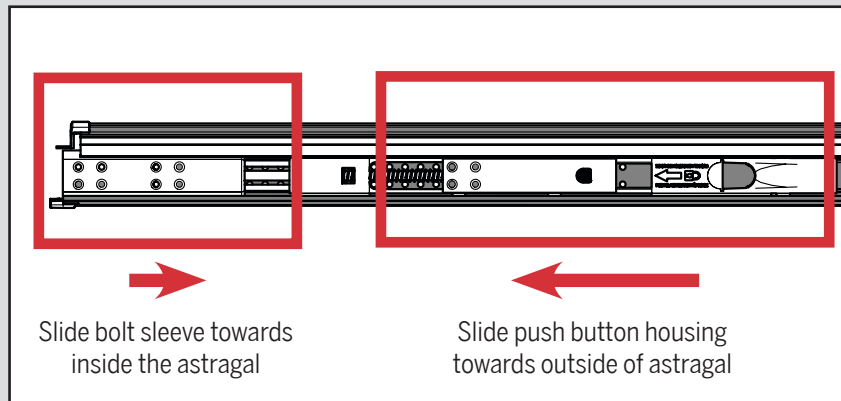

If the holes on the bolt do not align with the holes in the astragal body, adjust the location of the bolt sleeve and/or the push button housing to align the holes and then insert the orange securing pins. The bolt sleeve may be up to 1/4" inset from the end of the astragal.